

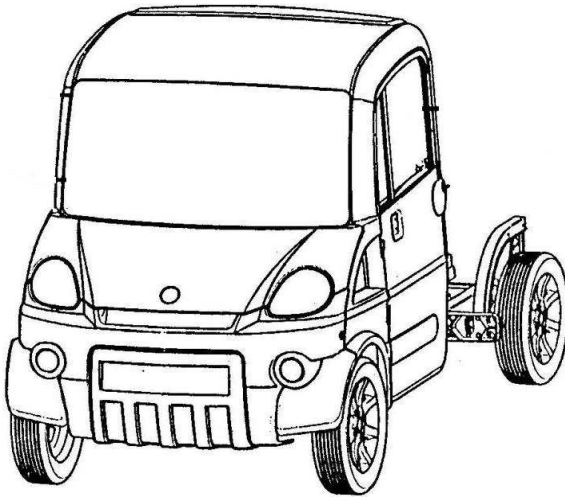

# MULTITRUCK



# MEGA

**Thank you for purchasing your MEGA vehicle and  
we hope you enjoy your driving experience.**

MEGA dealers should issue this handbook to all purchasers of a new vehicle. The information written on the Warranty card must be fully completed by the selling dealer at the time of purchase.

This handbook must be presented to your dealer for all service and warranty repair work carried out on the vehicle.

Please read the entire handbook carefully in order to fully familiarise yourself with the controls of your MEGA.

Follow the maintenance schedule in order to both protect and extend the life of the vehicle.

*[www.mega-vehicles.com](http://www.mega-vehicles.com)*



# **AIXAM MEGA**

56, route de Pugny – BP 112  
73101 AIX-LES-BAINS cedex  
France



## TABLE OF CONTENTS

	Diesel	Electric
Warranty card (detachable) .....	1,2	1,2
Warranty card .....	3	3
Table of contents .....	4	4
General warranty conditions .....	5,6	5,6
Traction battery warranty .....	-	7,8
Technical specifications (diesel versions).....	9,10	-
Technical specifications (electric versions) .....	-	11,13
Technical specifications (chassis cab) .....	14	14
Technical specifications (pick-up).....	15	15
Technical specifications (dropside).....	16	16
Technical specifications (van).....	17	17
Technical specifications (tipper) .....	18	18
Technical specifications (skip tipper).....	19	19
Weight.....	20,21	20,21
Pre-delivery checks.....	22	22
Service operations and schedule (diesel versions) .....	23,24	-
Service operations and schedule (electric versions) .....	-	25,26
Service schedule.....	27,28	27,28
Capacities and fluids.....	29	29
Front doors .....	30,31	30,31
Rear doors .....	32,33	32,33
Seats.....	33	33
Seat Belts.....	34,35	34,35
Children's safety .....	36	36
Instrumentation (diesel versions).....	37to39	-
Instrumentation (electric versions).....	-	40to44
Dashboard instrumentation.....	45	45
Instrumentation .....	46	46
Ashtray and cigarette lighter .....	47	47
Driving (diesel versions).....	48to50	-
Driving (electric versions) .....	-	51to54
Heating and ventilation (diesel versions) .....	55	-
Heating and ventilation (electric versions) .....	-	56
Vehicle care .....	57	57
Fuse box (diesel versions).....	58	-
Fuse box (electric versions).....	-	59
Spare tyre .....	60,61	60,61
Checking fluid levels .....	62to65	62to65
Tipper specifications .....	66to74	66to74
Skip tipper specifications.....	75to82	75to82
Breakdown and towing.....	83	83
Vehicle identification .....	84	84
Notes.....	85,88	85,88

# **GENERAL WARRANTY CONDITIONS**

1. All new vehicles supplied by Aixam Mega are guaranteed for a period of two years from the date of delivery to the Customer, against any manufacturing defects. All spare parts supplied by Aixam Mega are guaranteed for a period of one year from the date of delivery to the Customer against any manufacturing defects.

2. In order to comply with the Aixam Mega warranty:

- The users handbook must show the details of the vehicle, the name and address of the registered owner and the agreed Aixam Mega dealer.
- The warranty card that is located inside this handbook must be completed, signed by the Customer and sent to Aixam Mega within 48 hours of purchase.

3. This warranty information may be requested by any dealer within the Authorised Aixam Mega dealer network.

4. To comply with the warranty conditions the vehicle must receive a service at an approved Aixam Mega dealer between 500-1000 kms. The Aixam Mega dealer will carry out the necessary checks and services recommended by the manufacturer for the relative mileage (for free, except consumables and small parts). After completion of the service the dealer will then stamp and sign the handbook in the designated area indicating the date and actual mileage of the vehicle at the time of service.

5. The warranty covers any replacement or rectification according to manufacturers' instructions for any parts acknowledged as faulty. These operations will be carried out free of charge. The cost of breakdown services and towing costs are not included.

6. Any replacement or rectification carried out during the first year of warranty will not extend the warranty.

7. Any parts replaced during the warranty become the property of the manufacturer in full.

8. The warranty is invalidated and Aixam Mega is discharged from any responsibility under the warranty agreement:

- If the specification of the vehicle has been modified or altered in such a way as to no longer be in compliance with the original homologation.

- If non-original parts not supplied by Aixam Mega have been fitted to the vehicle.
- When damage caused by industrial pollution, acids, alkaline, chemicals, resins, bird droppings, salt, hail, storms, lightning and others that may affect the condition of the vehicle.
- If the service schedule has not been respected
- If a service has not been carried out in compliance with the service schedule
- If a service has been carried out by an agent who is not an Aixam Mega Authorised Dealer.
- If a carburant or lubricant other than those recommended by the manufacturer has been used or a carburant or lubricant that has impurities or foreign bodies.
- If the vehicle has been overloaded.

#### Other faults not included in the warranty

- All general maintenance and service elements including the setting and balancing of the wheels, engine adjustments, headlamp adjustments, the replacement of glow plugs, light bulbs, drive belts, transmission belts, brake pads, brake shoes, brake discs, brake drums, lubricants and fluids (brake fluid, gearbox fluid, windscreen wash fluid, cooling fluids)
- Normal wear and tear of any elements including; exhausts, belts, shock absorbers, as well as the wear and tear of seating, internal decorative panels, paint, wheel trims, or rims.
- Any vehicle where the Milo meter has been replaced or modified preventing a clear reading of the exact mileage, or where the vehicle serial number has been modified.
- Any cost resulting from the vehicle being immobilised, or any losses direct, indirect or commercial faced by the Customer.

10. A user's handbook is supplied with every new Aixam Mega vehicle, detailing maintenance, driving and warranty conditions. The warranty can only be authorised upon presentation of this handbook at the time of claims.

# **TRACTION BATTERY CONDITIONS**

The traction batteries benefit from specific warranty conditions

12 battery pack: 2 years, or a cumulated charge of 73 500 Ah whichever occurs first for both parts and labour.

8 battery pack: 2 years, or a cumulated charge of 49 000 Ah whichever occurs first for both parts and labour.

The warranty on the traction batteries commences on the date of 1<sup>st</sup> delivery to the Customer of the new vehicle, or on the date of installation of the new batteries in the case where defective or flat batteries have been replaced.

## **Cumulated Discharged Amp Hours**

The cumulated discharged Amp Hours is stored in the battery management calculator. The discharged Ah counter can be visualised on the monitoring screen of the Mega Diag Diagnostic software that is at the disposal of all Aixam Mega Authorised Dealers, or on the monitoring screen of the Mega Diag LIGHT Diagnostic software that is at the disposal of professional fleet end users.

Before any delivery or handing over of a new vehicle, the Authorised Dealer must generate a Mega Diag report on which must figure the Ah discharge counter reading. This report must be sent to the manufacturer.

## **Faults generated by the Operator or User that may invalidate the traction battery warranty:**

The battery packs are very sensitive to excessive discharges. In addition to the power level gauge, several warning levels inform the user as to the state of the batteries.

**First Level:** as soon as the power of one of the 4 groups of batteries goes below 11.3 V for more than two seconds, or if the current exceeds a certain level then the pre-warning indicator light called ECO comes on: it switches itself off as soon as the power (voltage and/or current) rises above this level.

**Second Level:** as soon as the power of one of the 4 groups of batteries becomes less than 10.5 V for more than two seconds, then the pre-warning light ECO remains on, and the General Fault indicator will light up. This warning light indicates that the user must stop immediately. A vehicle fault no.1.1, 1.2, 1.3 or 1.4 is then generated in the calculator and cumulated in the faults history (see Mega Diag Monitoring Screen). The warranty is invalidated if the number of fault n°1.1, 1.2, 1.3 and 1.4 registered is equal or more than 10 per month (divide

the number of faults by the number of months that the batteries have been in operation).

Third level: as soon as the power in one of the 4 groups of batteries is less than 0.5 V then the vehicle fault number 4.1, 4.2, 4.3 or 4.4 is generated in the calculator. This fault is stored in the faults history of the calculator (see Mega Diag Monitoring Screen). The warranty is invalidated if the number of only one of these faults 4.1, 4.2, 4.3 or 4.4 is equal to or more than 1.

### **Battery replacement**

Before replacing the batteries the Aixam Mega Authorised Dealer must generate a Mega Diag report.

Immediately after replacing the batteries the Aixam Mega Authorised Dealers must enter into contact with Aixam Mega After Sales Service in order to update the battery serial numbers in the controller. This is carried out using the Mega Diag software.

During this updating, the historic default values, which can cancel the warranty, are reset to zero. At the end of this update, the Aixam Mega Authorised Dealer will generate a second Mega Diag report.

The two reports “before replacing the batteries” and “after replacing the batteries” must be sent immediately to the Aixam Mega After Sales Service with the relevant warranty reimbursement request

## TECHNICAL SPECIFICATIONS

### DIESEL VERSIONS

MOTORISATIONS	400	600
Make	Kubota Diesel	
Type	Z402	Z602
Position	Transverse central	
Capacity (cm <sup>3</sup> )	400	599
Bore (mm)	64	72
Stroke (mm)	62,8	73,6
Number of cylinders	2 in line	
Maximum Power (kW CEE)	4	11,2
Maximum Power (hp)	5,4	15,2
Engine speed under max load (rpm)	3200	3600
Maximum torque (N/m CEE)	14	34
Engine speed at maximum torque (rpmm)	2400	2200
Max revs (rpm)	3200	3600
Fuel supply	Indirect Injection	
Cooling system	Liquid	
Alternator	500 Watts	
Service Battery	12V 40Ah	

## TECHNICAL SPECIFICATIONS

### DIESEL VERSIONS

MOTORISATIONS	400	600
Transmission	Automatic by variators	
Traction	Front wheel drive	
Gear arrangement	1 Forward + 1 neutral + 1 Reverse	
Gear ratio	1/12	1/10
Braking	Double circuit with limiter through load sensing valve and low level wear indicators to front brake pads	
Front disc diameter (mm)	210	240
Rear drum diameter (mm)	160	
Suspensions	Hydraulic shock absorbers with coil springs	
Front	Independent pseudo MacPherson strut type	
Rear	Independent with arms	
Maximum speed (km/h)	45	75
Fuel consumption per 100 km (litre)	3,5	4,5
Capacité du réservoir (litre)	24	
Miles per gallon	Approx 80	Approx 60
Carburant	Gazole (EN 590 standard)	

## TECHNICAL SPECIFICATIONS

### EILECTRIC VERSIONS

HOMOLOGATION TYPE		L6e*	L7e**	L6e*	L7e**
Number of traction batteries		8	8	12	12
Motor	Make	Advanced Technology			
	Type	Sepex CC			
	Maintenance	Brushes (10000 hours)			
	Cooling	Air fan			
	Max power	4 kW/ 5,4 hp			
Speed controller	Make	Curtis			
	Type	SEPEX			
	Maintenance	Maintenance free			
	Cooling	Air			
Traction battery	Make	Exide GNB			
	Type	AGM			
	Maintenance	Maintenance free			
	Recharge time	8 hours		10 hours	
	Energy on board	6,7 kWh		10 kWh	
	Vehicle selfdischarge	Between 5% and 10% per week			
	Voltage	Single 12 V, pack 48 V			
	Capacity	Single 70 Ah @ c 3, pack 140 Ah		Single 70 Ah @ c 3, pack 210 Ah	
	Pack weight	200 kg		300 kg	

\* L6e = Light Quadricycles with engine

\*\* L7e = Heavy Quadricycles with engine for good transport

## TECHNICAL SPECIFICATIONS

### ELECTRIC VERSIONS

HOMOLOGATION TYPE		L6e*	L7e**	L6e*	L7e**
No of traction batteries		8	8	12	12
Calculator	Make	EVE			
	Type	On board Calculator			
	Maintenance	Maintenance free			
	Cooling	No cooling			
Charger	Make	Charis 2 48HF30/EVE			
	Type	High frequency Charger			
	Maintenance	Maintenance free			
	Cooling	twin fan			
	Power	1500 W			
Reduction unit	Make	Comex			
	Ratio	1/8.4			
	Drive	Front wheel drive			
Accessories Battery		12 V 40 Ah			
Braking		Double circuit with limiter through load sensing valve and low level wear indicators to front brake pads			
Front disc diameter		240 mm			
Rear drum diameter		160 mm			

## TECHNICAL SPECIFICATIONS

### ELECTRIC VERSIONS

HOMOLOGATION TYPE	L6e*	L7e**	L6e*	L7e**
No of traction batteries	8	8	12	12
Suspensions	Hydraulic shock absorbers with coil springs			
Front	Independant pseudo MAC PHERSON strut type			
Rear	Independant with arms			
Max speed	45 km/h			
Range at full authorized weight	Up to 55 km***		Up to 80 km***	
Max incline when empty	>20 %		>20 %	
Max incline at full authorized weight	18 %		18 %	

\*\*\* Professional use, range depends on the use. Please consult us

# TECHNICAL CHARACTERISTICS

## Chassis cab

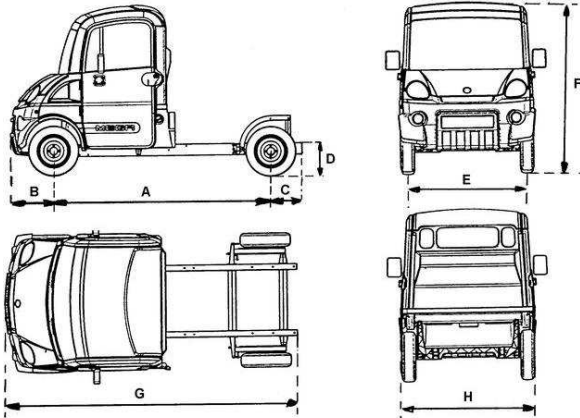

DIMENSIONS (mm)		Z402	Z602	Electric	Electric
				8 battery	12 battery
A	Wheelbase	2325	2325	2325	2325
B	Front Overhang	443	443	443	443
C	Rear Overhang	334	334	334	334
D	Height from ground to trunk floor	380	380	380	380
E	Front Track	1299	1299	1299	1299
	Rear Track	1273	1273	1273	1273
F	Overall Height	1800	1800	1800	1800
G	Overall Length	3102	3102	3102	3102
H	Overall width	1476	1476	1476	1476
<b>Maximum dimensions for custom build</b>					
C	Max Rear Overhang	985	985	985	985
F	Max Overall Height	2500	2500	2500	2500
G	Max Overall Length	3753	3753	3753	3753
H	Max Overall Width	1550	1550	1550	1550
<b>Position centre of gravity with respect to front load limits</b>					
	Maximum	2060	2060	2060	2060
	Minimum	1930	1930	1930	1930

# TECHNICAL CHARACTERISTICS

## Pick-up

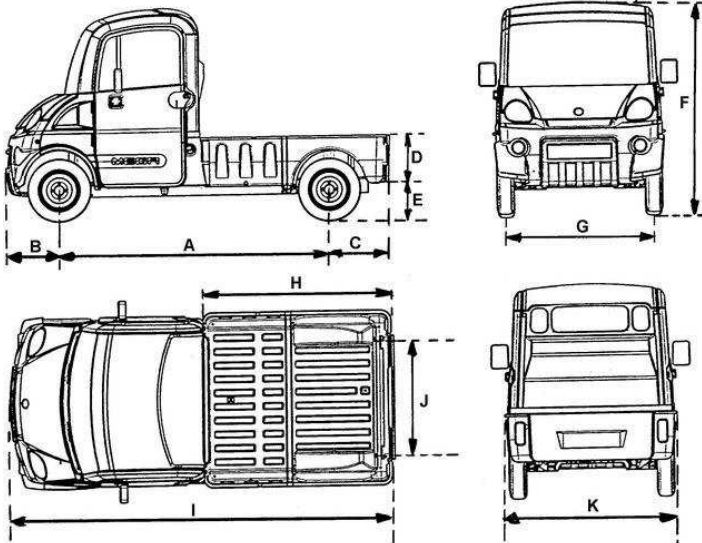

	<b>DIMENSIONS (mm)</b>	<b>Z402</b>	<b>Z602</b>	<b>Electric 8 battery</b>	<b>Electric 12 battery</b>
A	Wheelbase	2325	2325	2325	2325
B	Front Overhang	443	443	443	443
C	Rear Overhang	520	520	520	520
D	Height from ground to trunk floor	380	380	480	480
E	Height Pick Up sides	360	360	260	260
F	Front Track	1299	1299	1299	1299
	Rear Track	1273	1273	1273	1273
G	Overall Height	1800	1800	1800	1800
H	Length load bed	1520	1520	1520	1520
I	Overall Length	3288	3288	3288	3288
	Minimum interior bed width	900	900	900	900
J	Maximum interior bed width	1377	1377	1377	1377
K	Overall width	1487	1487	1487	1487

# TECHNICAL CHARACTERISTICS

## Drop side

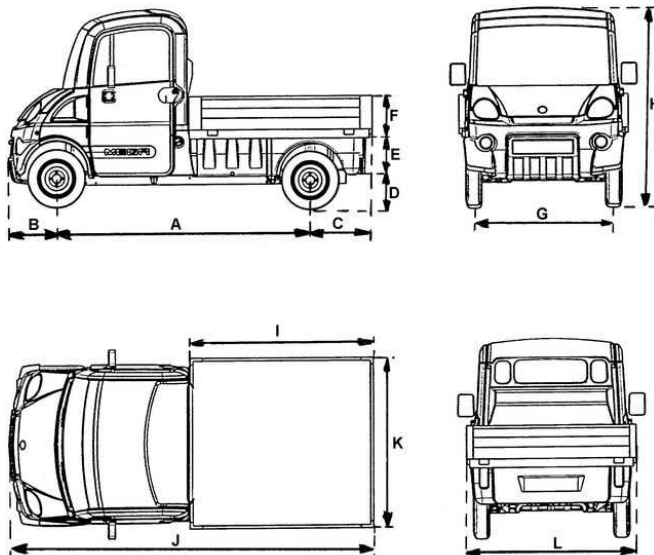

DIMENSIONS (mm)	Z402	Z602	Electric 8 battery	Electric 12 battery
A Wheelbase	2325	2325	2325	2325
B Front Overhang	443	443	443	443
C Rear Overhang	624	624	624	624
D Height from ground to trunk floor	380	380	480	480
E Height bed sides	360	360	260	260
F Height of side panels	280+/- 10	280+/- 10	280+/- 10	280+/- 10
G Front Track	1299	1299	1299	1299
Rear Track	1273	1273	1273	1273
H Overall Height	1800	1800	1800	1800
I Length load bed	1630	1630	1630	1630
J Overall Length	3331	3331	3331	3331
K Bed width	1488	1488	1488	1488
L Overall width	1545	1545	1545	1545

# TECHNICAL CHARACTERISTICS

## Van

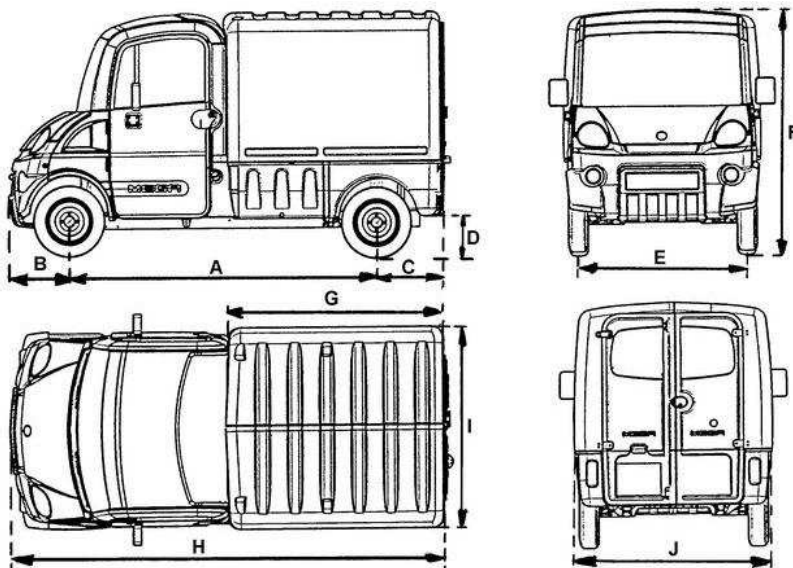

	<b>DIMENSIONS (mm)</b>	<b>Z402</b>	<b>Z602</b>	<b>Electric 8 battery</b>	<b>Electric 12 battery</b>
A	Wheelbase	2325	2325	2325	2325
B	Front Overhang	443	443	443	443
C	Rear Overhang	560	560	560	560
D	Height from ground to trunk floor	380	380	380	380
E	Front Track	1299	1299	1299	1299
	Rear Track	1273	1273	1273	1273
F	Overall Height	1800	1800	1800	1800
G	Length load bed	1505	1505	1505	1505
H	Overall Length	3328	3328	3328	3328
I	Bed width	900/1415	900/1415	900/1415	900/1415
J	Overall width	1490	1490	1490	1490

# TECHNICAL CHARACTERISTICS

## Tipper

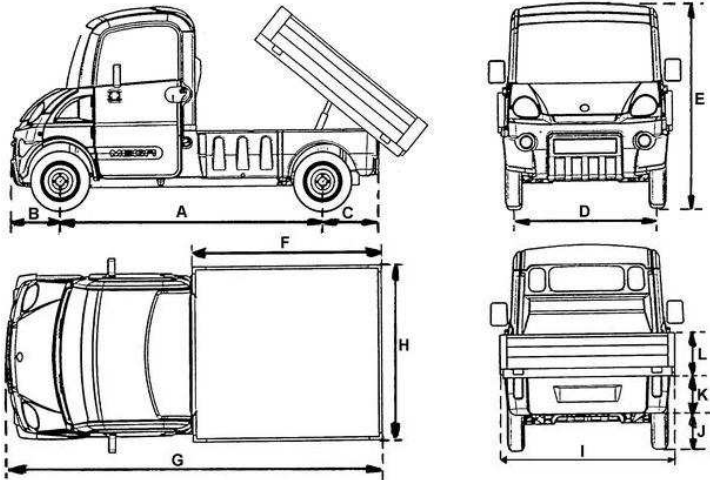

<b>DIMENSIONS (mm)</b>		<b>Z402</b>	<b>Z602</b>	<b>Electric 8 battery</b>	<b>Electric 12 battery</b>
A	Wheelbase	2325	2325	2325	2325
B	Front Overhang	443	443	443	443
C	Rear Overhang	624	624	624	624
D	Front Track	1299	1299	1299	1299
	Rear Track	1273	1273	1273	1273
E	Overall Height	1800	1800	1800	1800
F	Length load bed	1620	1620	1620	1620
G	Overall Length	3392	3392	3392	3392
H	Bed width	1490	1490	1490	1490
I	Overall width	1545	1545	1545	1545
J	Height from ground to trunk floor	380	380	380	380
K	Height bed sides	360	360	260	260
L	Height of side panels	280+/- 10	280+/- 10	280+/- 10	280+/- 10

# TECHNICAL CHARACTERISTICS

## Skip tipper

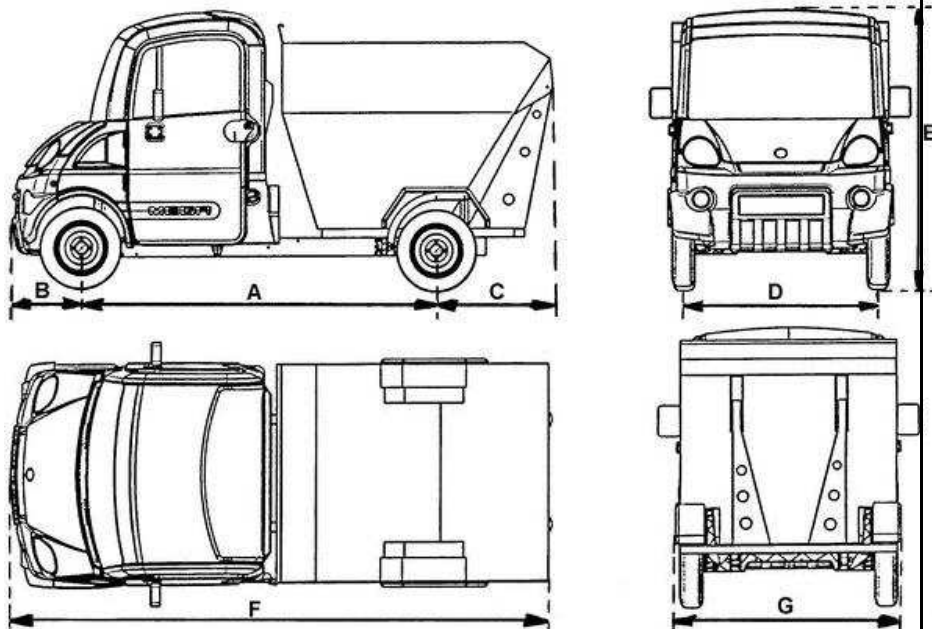

	<b>DIMENSIONS (mm)</b>	<b>Z402</b>	<b>Z602</b>	<b>Electric 8 battery</b>	<b>Electric 12 battery</b>
A	Wheelbase	2325	2325	2325	2325
B	Front Overhang	443	443	443	443
C	Rear Overhang	985	985	985	985
D	Front Track	1299	1299	1299	1299
	Rear Track	1273	1273	1273	1273
E	Overall Height	1800	1800	1800	1800
F	Overall Length	3573	3573	3573	3573
G	Overall width	1476	1476	1476	1476

### LIGHT QUADRICYCLES WEIGHT (L6e)

<b>DIESEL 400 (Z402)</b>	chassis cab	pick-up	Drop side	Van	Tipper	Skip tipper
Weight in unladen conditions (without driver) (kg)	380	410	460	465	–	–
Payload (kg)	275	245	195	190	–	–
Total authorised laden weight (kg)	655	655	655	655	–	–
Towing capacity (kg)	0	0	0	0	–	–
Front axle maximum authorised load (kg)	390	390	390	390	–	–
Rear axle maximum authorised load (kg)	450	450	450	450	–	–
<b>Electric 8 battery</b>	chassis cab	pick-up	Drop side	Van	Tipper	Skip tipper
Weight in unladen conditions (without driver) (kg)	590	620	670	675	–	–
Payload (kg)	275	245	195	190	–	–
Total authorised laden weight (kg)	865	865	865	865	–	–
Towing capacity (kg)	0	0	0	0	–	–
Front axle maximum authorised load (kg)	520	520	520	520	–	–
Rear axle maximum authorised load (kg)	690	690	690	690	–	–
<b>Electric 12 battery</b>	chassis cab	pick-up	Drop side	Van	Tipper	Skip tipper
Weight in unladen conditions (without driver) (kg)	700	730	780	785	–	–
Payload (kg)	275	245	195	190	–	–
Total authorised laden weight (kg)	975	975	975	975	–	–
Towing capacity (kg)	0	0	0	0	–	–
Front axle maximum authorised load (kg)	520	520	520	520	–	–
Rear axle maximum authorised load (kg)	690	690	690	690	–	–

## HEAVY QUADRICYCLES WEIGHTS (L7e)

<b>DIESEL 600 (Z602)</b>	chassis cab	pick-up	Drop side	Van	Tipper	Skip tipper
Weight in unladen conditions (without driver) (kg)	420	450	500	505	538	600
Payload (kg)	530	500	450	445	412	350
Total authorised laden weight (kg)	950	950	950	950	950	950
Towing capacity (kg)	0	0	0	0	0	0
Front axle maximum authorised load (kg)	475	475	475	475	475	475
Rear axle maximum authorised load (kg)	690	690	690	690	690	690
<b>Electric 8 battery</b>	chassis cab	pick-up	Drop side	Van	Tipper	Skip tipper
Weight in unladen conditions (without driver) (kg)	590	620	670	675	708	770
Payload (kg)	530	500	450	445	412	350
Total authorised laden weight (kg)	1120	1120	1120	1120	1120	1120
Towing capacity (kg)	0	0	0	0	0	0
Front axle maximum authorised load (kg)	520	520	520	520	520	520
Rear axle maximum authorised load (kg)	690	690	690	690	690	690
<b>Electric 12 battery</b>	chassis cab	pick-up	Drop side	Van	Tipper	Skip tipper
Weight in unladen conditions (without driver) (kg)	700	730	780	785	818	880
Payload (kg)	420	390	340	335	302	240
Total authorised laden weight (kg)	1120	1120	1120	1120	1120	1120
Towing capacity (kg)	0	0	0	0	0	0
Front axle maximum authorised load (kg)	520	520	520	520	520	520
Rear axle maximum authorised load (kg)	690	690	690	690	690	690

## VEHICLE PRE-DELIVERY CHECKS

Pre-delivery check operations are carried out by your MEGA dealer before delivering the vehicle for your full satisfaction

OPERATIONS	DIESEL	ÉLECTRIC
Check all doors and bonnet for fit and correct operation	X	X
Check instrumentation	X	X
Check fluid levels:		
▪ Engine oil	X	
▪ Transmission oil	X	
▪ Reduction unit oil		X
▪ Brake fluid	X	X
▪ Windscreen wash	X	X
▪ Cooling fluid and anti freeze	X	
Check for leaks:		
▪ Braking system	X	X
▪ Cooling system	X	
Check tyre pressure (including spare)	X	X
Check wheel nut torque, steering joints, transmission, reduction unit, major components security and general fittings	X	X
Check electrical components and headlamps	X	X
Check idling speed	X	
Check steering alignment	X	X
Print out Megadiag report		X
Test drive vehicle	X	X

### YOUR MEGA VEHICLE MUST BE SERVICED BY A MEGA APPOINTED DEALER

For greater reliability, use only genuine MEGA parts.

Electric Mega: when handing over the vehicle and in order for you to fully optimise its potential, your Mega distributor should inform you (and all the potential users of the vehicle) of the workings and the rules which must be complied with.

## MAINTENANCE ITEMS PERFORMED DURING SERVICE

<b>Diesel vehicles</b>			
<u>CHECKS AND SERVICE OPERATIONS TO BE PERFORMED DURING ROUTINE MAINTENANCE</u>	1st SERVICE BETWEEN 500 and 1000 km	5000 km and EVERY 5000 km SERVICE	ADDITIONAL OPERATIONS AT 10,000 km and EVERY 10,000 km
Change engine oil and filter element	●	●	
Change transmission oil	●	●	●
Check and top-up transmission oil level if necessary		●	
Check coolant level and top-up if necessary	●	●	
Check coolant system for leaks	●	●	
Check brake fluid level, top-up if necessary	●	●	
Check brake system for visible leaks	●	●	
Check brake efficiency including hand brake	●	●	
Clean and inspect brake drums, replace worn components as necessary at extra charge			●
Check electrolyte level of battery, top-up with demineralised water if necessary			●
Clean and lubricate battery terminals			●
Check drive belt condition, replace if necessary		●	
Check wheel nut torque and general security of all fittings	●	●	

## Diesel vehicles

<u>CHECKS AND SERVICE OPERATIONS TO BE PERFORMED DURING ROUTINE MAINTENANCE</u>	1st SERVICE BETWEEN 500 and 1000 km	5000 km and EVERY 5000 km SERVICE	ADDITIONAL OPERATIONS AT 10,000 km and EVERY 10,000 km
Clean or replace air filter element		● Clean	● Replace
Replace diesel filter element		●	
Check all tyre pressures including spare	●	●	
Check front wheel alignment and adjust if necessary	●	●	
Check and clean front pulley		●	
Check, clean and lubricate rear pulley		●	
Check front pulley for play and replace wear washers if necessary			●
Check electrical system	●	●	
Check all lights, instruments and accessories	●	●	
Road test vehicle	●	●	

**ATTENTION:** Maintenance operations in addition to service schedule

Every year: Replace brake fluid

Every 2 years: Replace coolant fluid



**NEVER USE 4-STAR PETROL OR UNLEADED PETROL AS ANTI-FREEZE IN DIESEL OIL. ONLY USE PRODUCTS RECOMMENDED FOR THIS PURPOSE. ALWAYS RESPECT THE INSTRUCTIONS PROVIDED BY THE MANUFACTURER OF THESE PRODUCTS.**

Attention: when using the vehicle in dusty conditions increase service frequency.

**The non compliance with this condition could invalidate the warranty.**

## MAINTENANCE ITEMS PERFORMED DURING SERVICE

<b><u>Electric vehicles</u></b>			
<b><u>CHECKS AND SERVICE OPERATIONS TO BE PERFORMED DURING ROUTINE MAINTENANCE</u></b>	<b>1st SERVICE BETWEEN 500 and 1000 km</b>	<b>Inspection Visit Every Six Months</b>	<b>Service at 5000km and every 5000 km (or 1 year)</b>
Change reduction unit oil	●		●
Check the security of the pod and clean the main batteries	●		●
Check the battery history and vehicle faults	●	●	●
Carry out Mega Diag check	●	●	●
Check brake fluid level, top-up if necessary	●		●
Check brake system for leaks	●		●
Check brake efficiency including hand brake	●		●
Clean and inspect brakes drums, replace any worn components as necessary at extra charge			●
Check, clean and lubricate battery terminals			●
Check wheel nut torque and general security of all fittings	●		●
Check electric power circuit	●	●	●

## Electric vehicles

<u>CHECKS AND SERVICE OPERATIONS TO BE PERFORMED DURING ROUTINE MAINTENANCE</u>	1st SERVICE BETWEEN 500 and 1000 km	Inspection Visit Every Six Months	Service at 5000km and every 5000 km (or 1 year) <sup>25</sup>
Check all tyre pressures including spare	●		●
Check wheel alignment and adjust if necessary	●		●
Check all lights, instruments and accessories	●		●
Test accessory battery and clean terminals	●		●
Clean the electric components tray completely	●	●	●
Clean the motor brushes area			●
Carry out a full charge on traction batteries	●	●	●
Road test vehicle	●	●	●

**ATTENTION:** Maintenance operations in addition to service schedule  
Every year: Replace brake fluid



**NEVER STOCK VEHICLE BATTERIES DISCHARGED** (auto discharge of 5% to 8% each week). **PLUG IT TO THE MAINS.**

**NEVER USE METAL TOOLS OR OBJECTS IN THE BATTERY COMPARTMENT OR IN THE AREA OF THE MOTOR WITHOUT DISCONNECTING**

## SERVICE SCHEDULE

26 500 – 1000 km Service DATE: KM:  Stamp and signature	5000 km Service DATE: KM:  Stamp and signature	10,000 km Service DATE: KM:  Stamp and signature
15,000 km Service DATE: KM:  Stamp and signature	20,000 km Service DATE: KM:  Stamp and signature	25,000 km Service DATE: KM:  Stamp and signature
30,000 km Service DATE: KM:  Stamp and signature	35,000 km Service DATE: KM:  Stamp and signature	40,000 km Service DATE: KM:  Stamp and signature
45,000 km Service DATE: KM:  Stamp and signature	50,000 km Service DATE: KM:  Stamp and signature	55,000 km Service DATE: KM:  Stamp and signature

## SERVICE SCHEDULE

<b><u>60,000 km Service</u></b> DATE: KM:  Stamp and signature	<b><u>65,000 km Service</u></b> DATE: KM:  Stamp and signature	<b><u>70,000 km Service</u></b> DATE: KM:  Stamp and signature
<b><u>75,000 km Service</u></b> DATE: KM:  Stamp and signature	<b><u>80,000 km Service</u></b> DATE: KM:  Stamp and signature	<b><u>85,000 km Service</u></b> DATE: KM:  Stamp and signature
<b><u>90,000 km Service</u></b> DATE: KM:  Stamp and signature	<b><u>95,000 km Service</u></b> DATE: KM:  Stamp and signature	<b><u>100,000 km Service</u></b> DATE: KM:  Stamp and signature
<b><u>105,000 km Service</u></b> DATE: KM:  Stamp and signature	<b><u>110,000 km Service</u></b> DATE: KM:  Stamp and signature	<b><u>115,000 km Service</u></b> DATE: KM:  Stamp and signature



**recommends the use of synthetic oils**

		CAPACITY		
		Diesel 400	Diesel 600	Electric
<b>ENGINE :</b> 100 % synthetic oil 5 W 50		1,2 litres	2,5 litres	
<b>Transmission or reducer unit :</b> 100 % synthetic oil 75 W 90		1,1 litre	1 litre	1 litre
<b>Coolant fluid</b>		2 litres	2,2 litres	
<b>Brake fluid:</b> DOT 4		0,3 litre	0,3 litre	0,3 litre

## FRONT DOORS

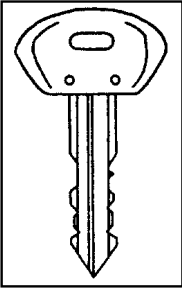

### KEYS

Four keys are supplied: two for the doors and two further keys for the fuel tank (diesel version).

Keep one set in a safe place as spare keys.

Depending on the version other keys may be supplied (rear van doors etc)

### LOCKING AND UNLOCKING DOOR FROM THE INSIDE

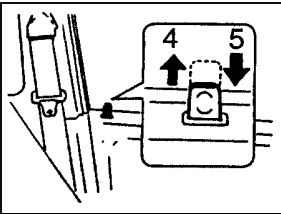

4. Unlock

5. Lock

### LOCKING AND UNLOCKING DOOR FROM THE OUTSIDE

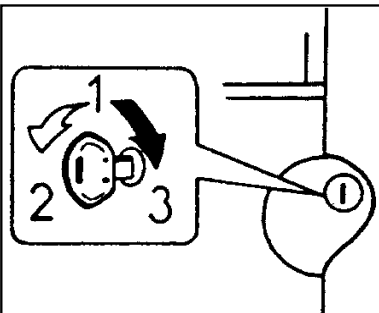

1. Introduce the key

2. Lock

3. Unlock

### OPENING AND CLOSING DOOR FROM OUTSIDE THE VEHICLE

Pull the handle towards you to open. To close, shut firmly and insure that the door is closed securely.

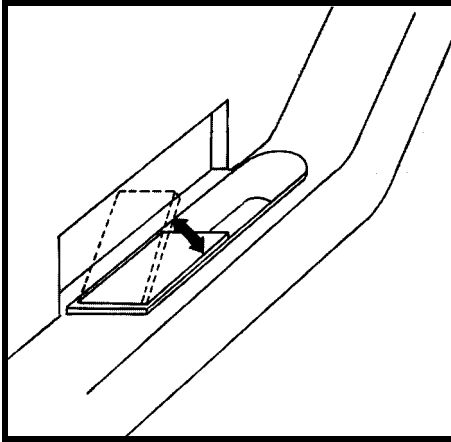

### **OPENING AND CLOSING DOOR FROM INSIDE THE VEHICLE**

To open the door, lift the latch situated on the armrest.

To close the door, pull the handle firmly towards you.

Always ensure that the door is properly closed before driving.

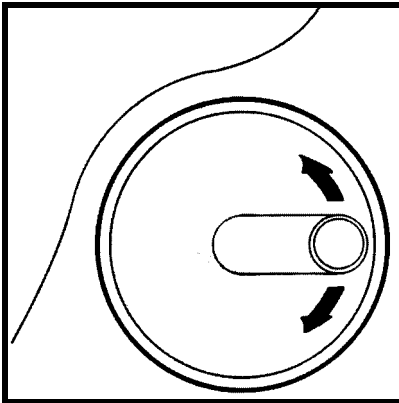

### **WINDOW WINDER**

To open the windows on the front doors, use the handle located on the inside of door;

## REAR DOOR

### OPENING AND CLOSING OF TAILGATE

- To open the rear door, use both hands and pull simultaneously on the two levers.
- Lower the door.
- To close, raise the rear door and click closed.
- Always ensure the rear door is securely closed.

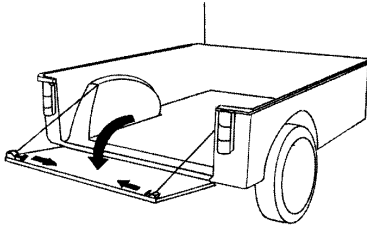

#### PICK-UP

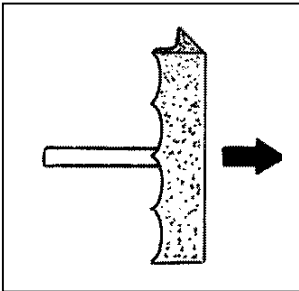

#### DROP SIDE

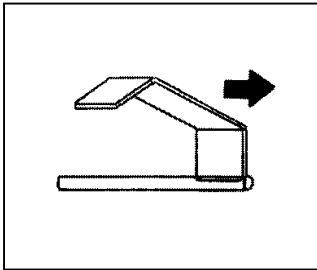

#### TIPPER

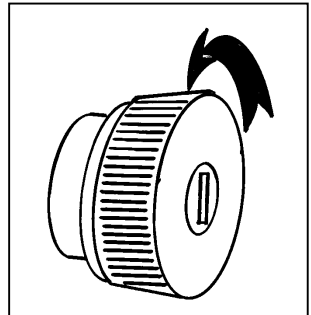

Open rear door handles for different models

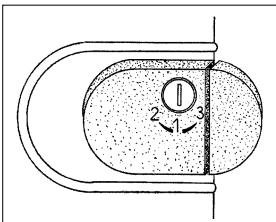

### LOCKING AND UNLOCKING OF REAR DOORS

1. Introduce the key into the lock
2. Lock
3. Unlock

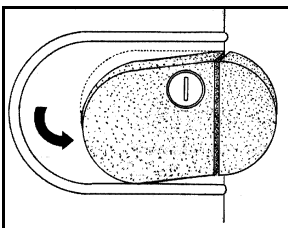

### OPENING AND CLOSING OF THE REAR DOOR FROM THE OUTSIDE

To open the door, pull towards you the door handle. To close push the door ensuring that it is firmly locked into place

**ATTENTION:**



Never drive with the rear door open because the licence plate will not be visible.

Never drive with the rear tailgate hanging down as it obstructs the rear lights and number plate.

Never put heavy objects on the rear door, whether open or closed.

Always ensure that load does not obstruct the rear lights or number plate.

**SEATS**

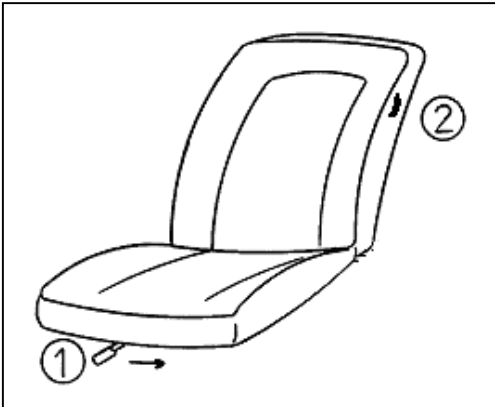

**ADJUSTMENT OF SEATS**

Adjust driver's seat to allow easy operation of pedals, steering wheel and driving controls on dashboard.

To adjust seat position move handle sideways and select position (1).

To lift seat forwards for access to motor area, adjust seat position (1) at maximum and lift lever (2).

**ATTENTION :**

- Adjust seat before driving.
- After adjusting, ensure that the seat is securely

# SEATS BELTS

## THREE POINT FIXING SAFETY BELT

This type of safety belt does not need to be adjusted to length. Once fastened, the belt will freely adjust to the users movements, but in the event of a sudden jolt will lock automatically to hold the body in position.

Before adjusting the length of the seat belt, first ensure you are sitting properly in the seat.

When attaching the seat belt, ensure that you are leaning back against the seat. The chest strap should be as close as possible, without restricting the neck. The abdominal strap should be placed flat against the thighs and abdomen.

The seat belt should be placed directly against the body. Avoid overly thick clothing, sharp objects, etc...

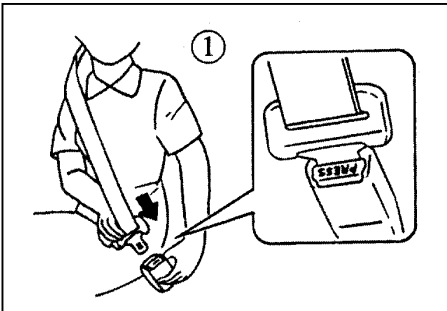

- (1) To fasten the seat belt, pull out the belt slowly and without pause, push buckle into lock until you hear a light click. If there is a block in the unrolling of the belt, rewind the belt to the rest position and pull out again.

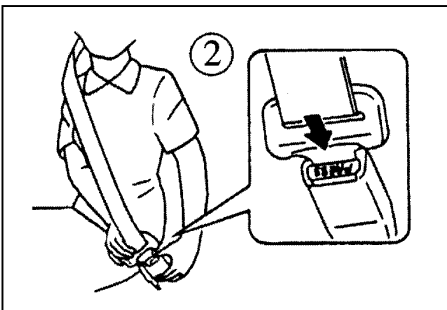

- (2) To unfasten the seat belt, push on the red button and release the buckle from the lock. As the seat belt rewinds allow the belt to gently return to the rest position.

**ATTENTION:** When the belt is not used, the belt buckle must be positioned near the fixing (3) thanks to the adjustable clip (A). When you leave the vehicle take care the belt is in correct position to avoid any belt jamming in the door.

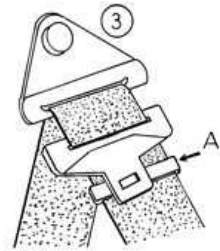

- Seat belts must be worn at all times when the vehicle is in motion.
- You must adhere to local safety belt legislation.
- The seat belt was designed to hold one passenger. Never place a child on your knees and attach the safety belt.

- Never use a device that interferes with the straps (eg: clothes peg) as there is a greater risk of injury in an accident if the seat belt is too loose.
- Following a serious accident, the seat belts in use at the time must be replaced. If any seat belt is faulty or damaged it must be replaced immediately.
- If it is necessary to clean the safety belts, use only soap and water, all other cleaning products are prohibited.
- Improperly adjusted seat belts may cause injury in an accident.
- Pregnant women must wear a seat belt. Adjust the abdominal strap to avoid putting too much pressure on the abdomen.
- When wearing seat belts ensure straps are not twisted.
- Do not attach the abdominal strap under the arm or behind the back.
- The seat belts were designed for use by occupants of adult height.
- Do not modify or alter the seat belt, its attachment to the vehicle or the seats. Only use the manufacturer original equipment.
- Babies and infants should never be transported on the knees of a vehicle occupant.
- It is particularly dangerous to strap in a child while he is seated on your knees. Never use one seat belt for more than one person at a time.
- Never leave a child or animal in a vehicle exposed to the sun with the windows closed.
- Never leave the keys with a child in the vehicle.

# **SEATS BELTS**

## **CHILD SAFETY**

- Child seats are not recommended for this vehicle.
- It is imperative to follow the laws of the local area in which you are driving, particularly in respect to driving with children of specific ages in the front seats of the vehicle.
- Generally, children younger than 12 years old, shorter than 1.5 metres or weighing less than 36 kgs, should be belted in with an approved safety device adapted to the weight and height of the child.
- The driver is responsible for the correct and proper use of the aforementioned safety device.
- It is advised to choose an approved safety device that follows the European Regulation ECE 44.
- Child safety devices are obliged to carry an orange ticket with the letter E followed by numbers (dependant of the authorised country) and the year of authorisation.

Age of child	Type approval category of child seat
from birth to 9 months weight less than 13 kg	"U" Universal back to the road type
from 9 months to 3 years weight 9kg to 18kg	"U" Universal
from 3 years to 12 years	"U" Universal

Before using a child's seat always ensure that it is correctly installed. Always refer to the manufacturer's installation instructions. Always ensure that the seat corresponds to the correct homologation category for the weight of the child.

# INSTRUMENTATION\*

Diesel versions

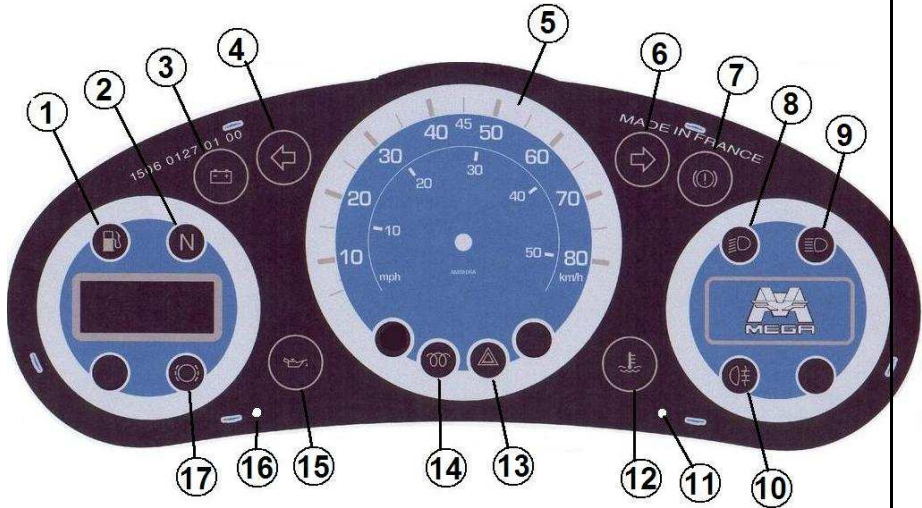

- (1) Fuel gauge
- (2) Neutral light
- (3) Battery charge light
- (4) Left indicator
- (5) Speedometer
- (6) Right indicator
- (7) Handbrake light
- (8) Main headlights indicator
- (9) High beam indicator
- (10) Fog light indicator\*
- (11) Right hand adjustment switch
- (12) Water temperature gauge
- (13) Warning lights indicator
- (14) Engine pre heat indicator
- (15) Oil pressure indicator
- (16) Left hand adjustment switch
- (17) Brake pad wear indicator

\*Depending on version

# **INSTRUMENTATION\* (continued)**

Diesel versions

## **LEFT SIDE SCREEN**

### **1. FUEL LEVEL INDICATOR**

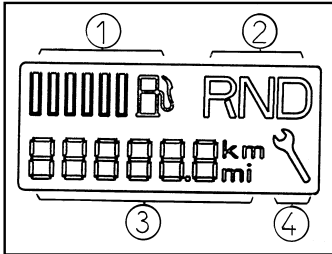

The level of fuel in the vehicle is shown by a bar graph type fuel level gauge (6 bars). As the fuel level falls the bars will no longer be shown. The minimum level is shown when the last bar flashes and when the fuel level indicator (shown by petrol pump) lights up. In this case you should re-fill the fuel tank as soon as possible.

### **2. GEAR SELECTION**

This indicates the gear that has been selected (forward, neutral, reverse). In addition to this when neutral is selected the indicator light (2 of previous page) lights up.

### **3. MILOMETER**

This is the total distance that the vehicle has covered. In order to obtain the daily tripmeter function, press lightly on the button (16 of previous page). In order to reset the daily tripmeter press lightly for a few seconds on this same button. In order to come back to the total distance reading, again press lightly on this button.

### **4.MAINTENANCE INDICATORS**

The maintenance indicator will inform you in advance when the next service should be carried out on your vehicle. Two parameters will be taken into account to calculate when the next service should be carried out: the time and the mileage. Example 1000 km or 1 year, 5000 km or 1 year.

This indicator will show the distance that is remaining before the next service is due for 5 seconds, after having switched the ignition onto position 2. The spanner sign (4) will also show. If the distance is reached or passed then the spanner light will show as well as the distance and a “ – “sign will flash for a period of 5 seconds. If the period in terms of time is reached or passed then the spanner sign as well as the message “1 year” will flash for 5 seconds, and the spanner sign will remain lit up. In order for your vehicle to be serviced urgently we advise that you make contact with your local Authorised Dealer.

\*depending on version

# **INSTRUMENTATION\*** (CONTINUED) Diesel versions

## **SIGNIFICANCE OF DANGER LIGHTS (RED COLOUR)**

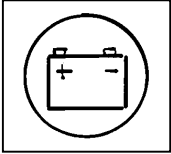

**Battery charge indicator:** (red light) Lights up when key is in position 2. It should extinguish when the engine runs. If the light remains illuminated, contact immediately the nearest MEGA service dealer.

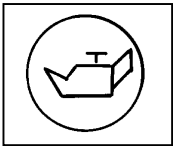

**Oil low-pressure warning:** (red light) Lights up when key in position 2 and should switch off as soon as the engine is started up. If it illuminates while driving, stop immediately. Check the level of oil in the engine and fill up if necessary. If the light stays illuminated with the correct oil level, contact immediately the nearest MEGA service dealer.

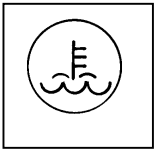

**Cooling fluid warning:** Lights up when key in position 2 and should switch off as soon as the engine is started. If this light illuminates while driving then stop immediately. Wait 30 minutes before checking the cooling fluid level (risk of burns with hot liquid). If the light remains on after the check and topping up contact immediately your nearest MEGA service dealer.

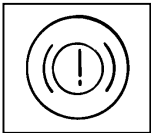

**Handbrake and brake fluid level light:** If illuminated then indicates that the handbrake has not been released or indicates that the brake fluid level is low. Top up with the recommended brake fluid.

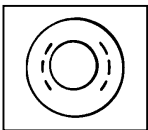

**Brake pad wear indicator:** If this light illuminates when braking, ensure that the brake pads are checked and replaced if necessary as soon as possible.

## INSTRUMENTATION\* (continued)

Electric versions

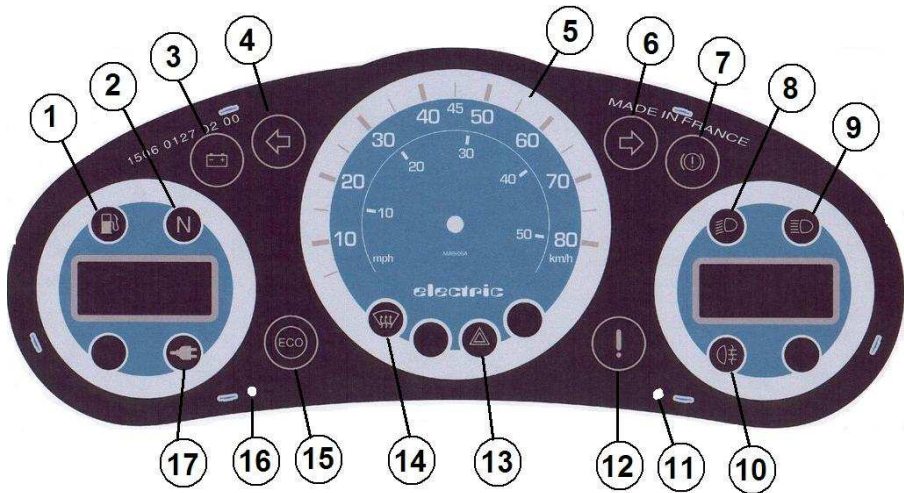

- (1) Minimum power level indicator
- (2) Neutral gear indicator
- (3) Accessory battery charge warning light
- (4) Left indicator
- (5) Speedometer
- (6) Right indicator
- (7) Handbrake light
- (8) Dipped beam light
- (9) Full beam indicator
- (10) Fog light indicator \*
- (11) Right setting button
- (12) General fault warning light
- (13) Warning light indicator
- (14) Rear windscreen de-icing indicator
- (15) Intensive use warning indicator
- (16) Left setting button
- (17) Traction Battery charge indicator

\*depending on version

# **INSTRUMENTATION\* (continued)**

Electric versions

## **LEFT SIDE SCREEN**

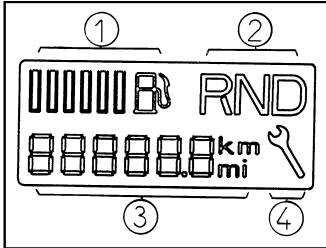

### **1. Electric energy gauge**

- 6 segments = level > 84%
- 5 segments = level > 68%
- 4 segments = level > 52%
- 3 segments = level > 36%
- 2 segments = level > 20%
- 1 segment = level < 20 %

### **2. Drive Direction**

Indicates the drive direction that is selected (forward, neutral, reverse). Together with the neutral position indicator an indicator on the dashboard instrument panel lights up (no.2 on page 40).

### **3. Speedometer partial**

Vehicle mileage display: showing of trip distance covered.  
To reset the tripmeter press lightly for a few seconds on the reset button.

### **Maintenance Indicator**

The maintenance indicator will indicate when the next service should be carried out on your vehicle. Two parameters will be taken into account to calculate when the next service should be carried out: the time and the mileage. Example 1000 km or 1 year, 5000 km or 1 year.

This indicator will show the distance that is remaining before the next service is due for 5 seconds after switching the ignition to position 2. The spanner sign (4) will also show. If the distance is reached or passed then the spanner light will show as well as the distance and a “ – ” sign will flash for a period of 5 seconds. If the period in terms of time is reached or passed then the spanner sign as well as the message “1 year” will flash for 5 seconds, and the spanner sign will remain lit up. In order for your vehicle to be serviced urgently we advise that you make contact with your local Authorised Dealer.

\* depending on version

# **INSTRUMENTATION\*** (CONTINUED) Electric versions

## **RIGHT SIDE SCREEN**

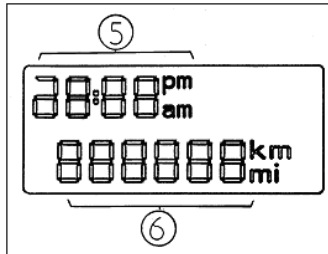

### **5. The Clock**

The adjusting of the clock can only take place with the vehicle stationary, using the following procedure.

- Press the button 11 (see page 24) for 3 seconds and the hours will flash.
- Pulse the button to adjust the hours. Confirm the hours by pressing for a few seconds on the button
- Proceed in the same way to adjust the minutes. To finish confirm by pressing the button for a few seconds.

### **6. Trip meter total**

#### Adjustment of instrumentation brightness

During the day when the lighting system is off, the lighting of the instrumentation cannot be adjusted.

At night once the lighting system is functioning you can adjust the intensity of the lighting. To adjust, press repeatedly on button 11 (see page 24). The brightness will increase with each press until it reaches maximum intensity and then will revert to minimum intensity.

\* depending on version

# **INSTRUMENTATION\*** (CONTINUED) Electric versions

## **SIGNIFICANCE OF DANGER LIGHTS** (RED COLOUR)

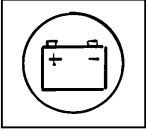

**Battery charge indicator:** Lights up with ignition switch in position 2 but should extinguish when the engine is running. If the light remains illuminated contact the nearest MEGA dealer.

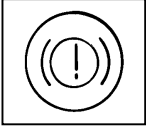

**Brake Fluid and Handbrake warning Light:** If illuminated then indicates that the handbrake has not been released or indicates that the brake fluid level is low. Top up with the recommended brake fluid (see page 29).

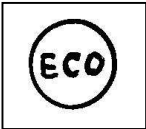

**Econometer Warning Light:** Illuminates when the vehicle is driven aggressively, meaning an intensive energy consumption, or when you approach the end of range.



### **General Fault warning Light:**

1. If this lights up while vehicle is moving: **stop the vehicle as soon as it is safe to do so.**

1.1 If this light and the econometer light are both illuminated this means that you have reached the limit of the range of the vehicle. Recharge the vehicle (otherwise risk of permanent damage to the traction batteries – see traction battery warranty conditions).

1.2 If only this light is illuminated, contact immediately the nearest Mega dealer.

#### **Possible causes**

- Motor temperature is too high (let him cool)
- Controller Unit fault
- Traction battery tension issue

2. It lights up during charging:

This warning indicates a charging fault. The range of your vehicle risks being reduced. The warning light may come on again whilst driving. If

this occurs stop immediately. Contact immediately your nearest MEGA dealer

## **SIGNIFICANCE OF WARNING LIGHTS** (Orange colour)

### **Battery charge indicator:**

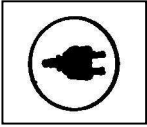

- Regular flashing = vehicle charging
- Fixed light = vehicle fully charged
- Double flash + pause = charge interrupted due to high temperature of traction batteries.
- Triple flash + pause = time exceeded normal time of one of the charging phases.

If after 10 hours of recharge this indicator is not fixed illuminating, contact immediately your nearest Mega dealer (range may be reduced – risk of battery damaging).

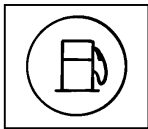

### **Battery energy level gauge**

If this light is illuminated it means that the traction battery capacity is less than 20% of total capacity. Recharge the vehicle as soon as possible.

**INSTRUMENTATION\*** (CONTINUED)  
All versions

**SIGNIFICANCE OF OTHER LIGHTS**



Left indicator (green light)



Right indicator (green light)



Neutral Indicator Light



Fuel reserve (or energy reserve) indicator



Dipped beam indicator



Full beams (blue light)



Fog Light Indicator\*



Hazard Warning Lights



Heated Rear Window



Engine Pre-heat Operating

# INSTRUMENTATION

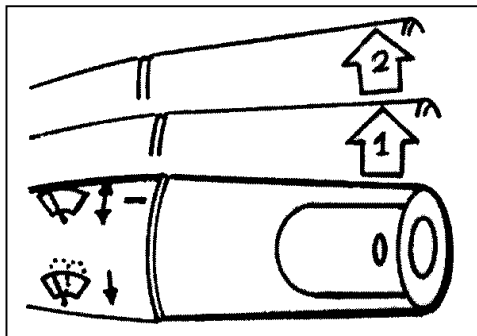

## WINDSHIELD WIPERS

- 0 – Stop
- 1 – Slow and intermittent speed
- 2 – Fast speed

Pulling lever towards you operates the windscreen wash facility

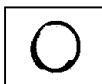
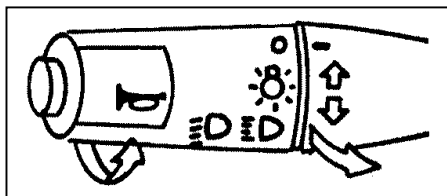

## LIGHTING

All lights off

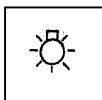

## Side light

Turn the control forward



## Headlights / on full beam

To change the lights from dipped to full beam, pull the lever towards you.

Upon opening the right door with engine off, signal sounds to indicate that the lights have not been extinguished.

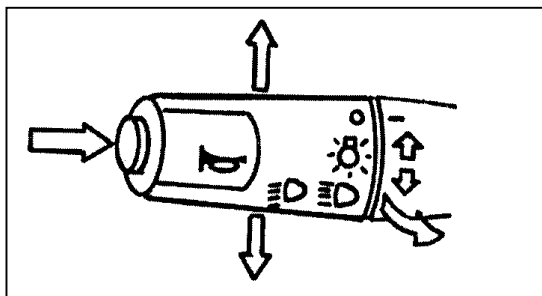

## HORN

Press on the end of the control.

## FLASH MAINBEAM

Pull forward on switch arm

## DIRECTIONAL INDICATORS

Left to the bottom – Right to the top.

When changing direction, move

the control in the appropriate direction; the control will return to its neutral position automatically when the turn is complete.

## CIGAR LIGHTER AND ASHTRAY

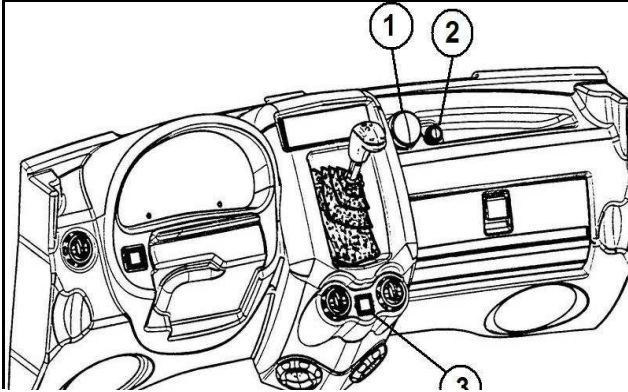

### CIGAR LIGHTER (1)

Push the cigar lighter in until it stops. It is ready to use when it pops back into its normal position and emits a gentle click. To use, remove the cigar lighter from its compartment.

### ATTENTION :

- Hold the cigar lighter by the button. Do not touch the metal casing, which can burn.
- Only use the original cigar lighter supplied with the vehicle, use of any other may be a fire hazard.
- Once the cigar lighter is pushed in, it should pop back into its normal position within 30 seconds, if it does not then it is faulty and should be pulled out immediately, as it is a fire hazard.

### ASHTRAY (2)

Pull forwards to open.

To remove the ashtray, grip the protruding handle and pull forward.

### HAZARD WARNING LIGHTS (3)

The control operates all four indicator lights simultaneously.

### INTERIOR LIGHTS

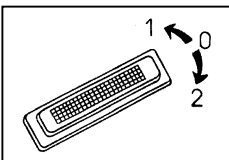

0 - OFF

1 - Permanently ON

2 - ON when the right door is opened

## DRIVING

Diesel versions

### STARTING

#### CONTACT, STARTING CONTROLS

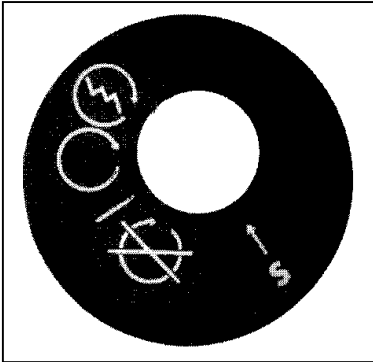

**S**



### ANTI-THEFT STEERING LOCK

To release the steering, lightly manoeuvre the steering wheel while turning the key gently.

### ACCESSORIES



#### CONTACT (Position 2)

Do not leave the control in this position when the engine is turned off: the battery may discharge.

### STARTER

Start with the key is in this position.

### STARTING AND STOPPING THE ENGINE

- Check first that the handbrake is engaged and the transmission is in neutral.
- Put the key in the  position and wait for the engine pre-heat indicator light to go out.
- Turn the key to  position. Release the key. Do not accelerate during this operation.
- To stop the engine, return the key to the **S** position.

### DRIVING ADVICE

- Before departing, check:
  - Position of rear-view mirror
  - Seat position
  - Fuel level
- Put on and adjust seat belt
- Drive using only one foot to avoid using both pedals (accelerator and brake) at the same time, which will avoid premature wear to both transmission and braking systems and also fuel high consumption.

# DRIVING

Diesel versions

## DRIVING ADVICE (continued)

- Reduce speed on descents.
- If you need to mount a kerb, carefully mount at the lowest possible point otherwise you risk damaging the suspension and prematurely wearing out tyres.

## CHANGING DIRECTIONS

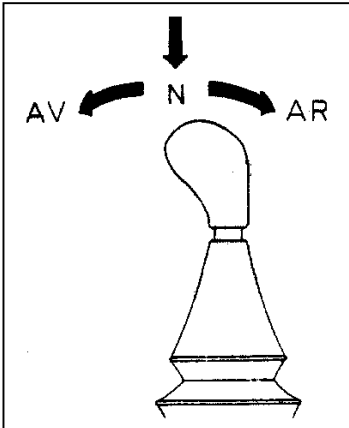

### **TO SELECT THE DESIRED GEAR:**

1. Push lever down and forward to select the forward gear. Example to engage from reverse gear to forward gear or to pass from neutral gear to forward gear.
2. Pull lever back to select neutral from forward gear.
3. Push lever down and back and then pull handle upwards to select and lock reverse gear.

## HANDBRAKE

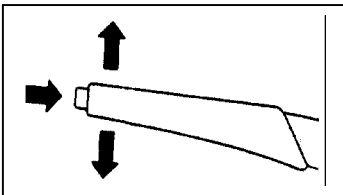

### **TO PARK, BRING THE VEHICLE TO A COMPLETE HALT AND APPLY THE HANDBRAKE.**

1. To apply the handbrake, pull the handle upwards without pressing the button on the end of the handle.
2. To disengage, pull the lever gently upwards and press on the button and lower the handle.

## **DRIVING**

### **Diesel versions**

#### **RECOMMENDATIONS FOR 'RUNNING IN THE VEHICLE'**

To ensure the vehicle remains reliable and economical, drive the vehicle as follows during the first 1000 km.

- Do not drive the vehicle at high speeds.
- Avoid rapid starts, and accelerating and braking excessively. Follow speed limits.
- Do not overload the vehicle.

#### **FUEL USED**

Diesel fuel (DIN 51601)

#### **REFUELLING**

- Stop the engine before refuelling.

**ATTENTION: The fuel is explosive and flammable. Extinguish all flames and abstain from smoking.**

- Unlock and remove the fuel tank cap located on the left of the vehicle.
- Insert the refuelling nozzle.
- After the automatic interruption in the flow of fuel from the service station pump do not continue to add any fuel for longer than 5 seconds.
- Remove the nozzle.
- Replace the fuel cap and lock.
- Remove any fuel spillage from the vehicle as quickly as possible with a dry cloth.

## DRIVING

Electric versions

### STARTING CONTACT, STARTING CONTROLS

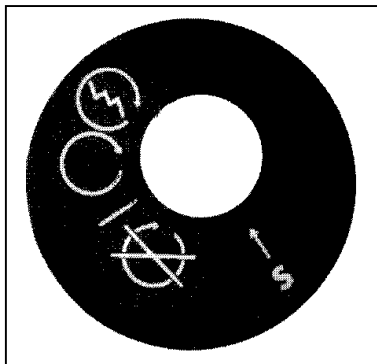

**S**



### ANTI-THEFT STEERING LOCK

To release the steering, lightly manoeuvre the steering wheel while turning the key gently.

### ACCESSORIES

### RUNNING POSITION

The contact is made. Do not leave the control in this position when the ignition switch is turned off: the battery may discharge.

### STARTER

Not used on electric versions

### STARTING AND STOPPING THE ENGINE

- Check first that the handbrake is disengaged.
- Put the key in the  position and wait for the closing of the principal contact (click) and the sound of the motor ventilator fan running.
- Always select direction using the gearshift lever without accelerating.
- To stop, return the key to the **S** position.
- With the contact on and the vehicle stationary, the ventilator will function. This will lead to a consumption of the energy and will contribute to a discharge of the traction batteries. Ensure therefore that the ignition switch is switched off once you arrive at the destination.

### DRIVING ADVICE

- Before departing, check:
  - Position of rear-view mirror
  - Seat position
  - Battery capacity level
- Put on and adjust seat belt
- Drive using only one foot, to avoid using both pedals (accelerator and brake) at the same time. Engaging both the accelerator and brakes at the same time will prematurely damage the vehicle systems and will lead to a reduction in the range of the vehicle caused by an excessive energy consumption and a range reduction.

# **DRIVING**

## **Electric versions**

### **DRIVING ADVICE** (cont'd)

- Reduce speed on descents.
- If you need to mount a kerb, carefully mount at the lowest possible point or else you risk damaging the suspension and prematurely wearing out the tyres.

### **CHANGING DIRECTIONS**

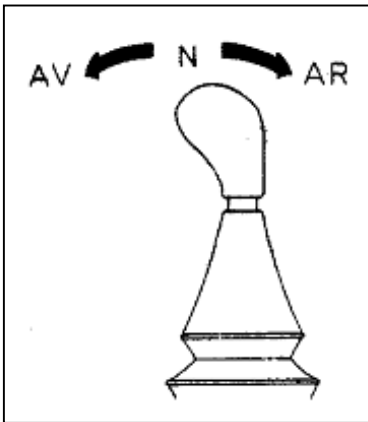

### **TO SELECT THE DESIRED GEAR:**

Once the ignition has been engaged you must select a gear to set off.

If forward gear had been selected when the ignition was being engaged, and you wish to go in a forward direction then, bring the gear lever into neutral position and then again into forward position. Then accelerate progressively. You must always move the gear lever in order for the vehicle to move.

### **HANDBRAKE**

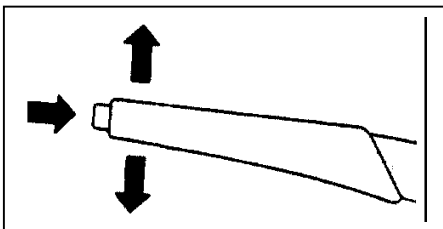

### **TO PARK, BRING THE VEHICLE TO A COMPLETE HALT AND ENGAGE THE HANDBRAKE.**

1. To apply the handbrake, pull the handle upwards without pressing the button on the end of the handle.
2. To disengage, pull the lever gently upwards, press on the button and lower the handle.

# **DRIVING**

## **Electric versions**

### **RECOMMENDATIONS FOR 'RUNNING THE VEHICLE IN'**

To ensure the vehicle remains reliable and economical, drive the vehicle as follows during the first 1000 km.

- Do not drive the vehicle at high speeds.
- Avoid rapid starts, accelerating and braking excessively. Follow speed limits.
- Do not exceed payload limits.
- The total authorised weight also includes the weight of the driver and passenger.

### **UTILISATION OF THE ELECTRIC VEHICLE**

The electric MEGA is simple to drive. It is equivalent to a conventional automatic transmission. There is a gear lever, accelerator and brake pedal.

### **THE TRACTION BATTERY:**

Correct use of the principal batteries, known as the traction batteries, are as follows:

- Determine if a partial charge will be needed during the day.
- When storing, leave the vehicle plugged in to the mains: the charger will restart periodically to maintain the charge on the batteries.
- Drive economically in order to limit charge demand on the traction batteries. Illuminated warning lights signify that the battery needs to be recharged to avoid damage.

### **THE HI/LO SPEED SELECTOR:**

- Whenever possible use the "LO" economical position on the switch "HI/LO" in order to maximise the range. The maximum speed is therefore limited to 30 km/h (19mph). The acceleration performance is also reduced compared to the HI position.
- The HI position corresponds to the maximum performance for the vehicle
- Do not drive when the General Fault Indicator  is illuminated.

## **DRIVING**

### **Electric versions**

- In winter or in low temperatures always store the vehicle inside, in order to maintain the range.
- When going downhill the regeneration of current through the braking system will cause a slowing down of the vehicle. This does not dispense you from using the mechanical brakes as failure to do so may result in “free wheeling”, especially after a complete charge.

By respecting these instructions you will lengthen the life of your traction batteries. **The non compliance with these instructions may invalidate the warranty of the batteries.**

### **RECHARGING THE BATTERY**

To charge the battery, plug into a 13 amp outlet. The charge starts automatically and the dashboard will light up to give indications relative to the charge. The strength of the charge is shown on the econometer and the level of the battery charge is shown on the gauge. The reserve indicator light will flicker when the battery is charging.

When the vehicle is charging an anti-start-up circuit will stop the motor from functioning.

The vehicle can be charged at any time and can be interrupted at any time. It is recommended to recharge the battery fully at least once a week, in order to maintain good battery condition.

### **AUXILLARY EQUIPMENT**

All auxiliary equipment uses energy from the traction batteries. Using the lights, windshield wipers and radio have a negligible effect on the vehicle autonomy. Only the heating system, which is electric and thereby instant, uses 15% of the autonomy per hour of use. When the vehicle reaches the limit of its range, the heating will be automatically cut by the on-board calculator. In the case where other auxiliary equipment connected to the auxiliary battery is used, it is important to note that it is only necessary to have the key in contact in position 2 to feed the auxiliary battery. Putting the vehicle in this contact position sets off the 48V/12V-300W converter. This component takes its energy from the traction batteries to recharge the auxiliary battery (12V)

The auxiliary battery is recharged when the traction batteries are charged.

# HEATING AND VENTILATION

Diesel versions

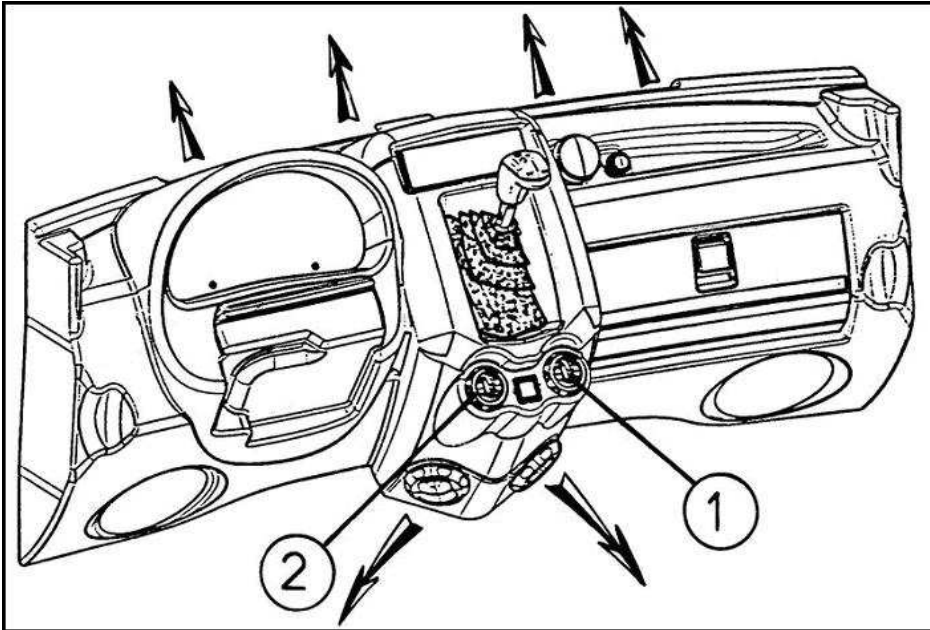

## 1- VENTILATION SWITCH

- 0 – off
- 1 – low speed
- 2 – medium speed
- 3 – high speed

## 2- HEATING SWITCH

Turning the switch to the right increases the air temperature in the cabin. The heating is only efficient when the engine is running. The performance of the heating system depends on the temperature of the cooling fluid. It is advised to use the heating once the engine has reached its normal working temperature.

In order to demist the windscreen more quickly, close the inside air vents.

# HEATING-VENTILATION

## Electric versions

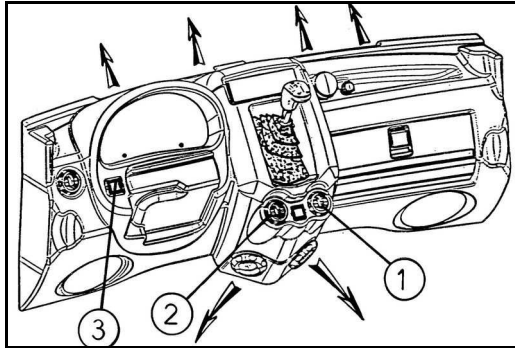

### 1- VENTILATION SWITCH

- 0 – off
- 1 – low speed
- 2 – medium speed
- 3 – high speed

### 2- HEATING ON/OFF SWITCH

The electric heater (750W) is instant. It is operational if the ventilator is open and if the ECO light is not illuminated. It is advisable to use the heating moderately, because it consumes, at full strength, 15% of the battery charge per hour of usage.

### 3- WINDSCREEN DE-ICING SWITCH

The windscreen de-icer (1500W) will start by pressing the switch and by switching on the ventilation. The de-icing function is time set and will switch off after 4 minutes. You can switch it off before by pressing the switch again. ATTENTION. Each time this function is used between 1-2% of the energy supply is used.

**ATTENTION : the heating will stop automatically when the electric energy ECO light is illuminated in order to save energy.**

## VEHICLE CARE

### ATTENTION :

The use of chemical products can be dangerous. Some are toxic; others ignite close to an open flame or heat sources. In poorly ventilated areas, inhalation of the fumes of particular substances can cause illness or poisoning. Read and follow directions carefully for all chemical products. When using, ensure proper ventilation, by opening doors and windows.

The following products are prohibited for use on the vehicle:

- Petrol
- Acetone
- Nail varnish remover
- Carbon tetrachlorine
- Varnish thinners
- Naphtha
- Teretentine essence
- Benzine
- Paint thinners
- Etc...

These products are dangerous and risk damaging the vehicle.

### CLEANING THE CABIN

Vacuum the cabin to remove dust. Clean plastic panes with soap and water. Clean the upholstery and carpets with cleaning products designed for that use.

### CLEANING THE BODY

Immediately clean the vehicle if it is exposed to elements that may corrode, discolour or stain the body, notably:

- Sea water, chemical products used for de-icing roads in winter;
- Soot and dust, ash, chemical products (acids, tar, etc..)
- Bird droppings, insect debris, tree resin, etc...

### CLEANING

- Use only liquid soap and water.
- Avoid direct sun or freezing temperatures.
- Do not use abrasive products (metal scrubbers, scouring powders, etc...)
- Do not use automatic car washes.
- Do not use steam or pressure washers.

### CLEANING OF WINDOWS

Clean windows with soap and water, or a suitable glass cleaner, taking care to avoid contact with the vehicle body.

# FUSE BOX

## Diesel versions

The fuse box is located behind the dashboard in the centre.

**ATTENTION :**

If a fuse blows, check the electric circuit of your vehicle on the MEGA wiring diagram.

**Fuse box configuration :**

20A	20A	15A	
F1	F2	F3	
10A	15A	20A	20A
F7	F8	F9	F10

+	Cont.ON	+	Cont.ON	+	Cont. ON	+	Cont. ON	+	PER
	C19-E1		C19-E2		C19-E3		4C19-E4		C18-E1
	F7 (10A) • Instrument panel		F8 (15A) • Alternator • Pre heat relay • Rear brake lights		F9 (20A) • windscreen viper • Reversing light* • Heating fan		F10 (20A)  Engine pre-heating		F1 (20A) • Engine stop system
	C19-S1		C19-S2		C19-S3		C19-S4		C18-S1

50A fuse: protects the entire electric circuit and is situated on the + battery terminal.

## **FUSE BOX**

### **Electric versions**

**1-** A fuse box protects the 12V circuit of the vehicle. It is located behind the dashboard in the centre.

C18-E1	C18-E2	C18-E3	C18-E4	C18-E5
F1	F2	F3	F4	F5
20A	15A	5A	15A	20A
12V	12V	12V	12V	12V
C18-51	C18-52	C18-53	C18-54	C18-55

- F1 20 AMP fuse protects: interior lighting, horn, headlamps.
- F2 15 AMP fuse protects: radio, cigar lighter, instrument panel lights
- F3 5 AMP fuse protects: components tray
- F4 15 AMP fuse protects: stop lights, automatic demisting relay
- F5 20 AMP fuse protects: windscreen wipers, heating ventilator.

50 AMP fuse: protects the entire electric circuit and is situated on the + accessories battery terminal.

**2-** A Fuse box protects the 48V circuit of the vehicle. It is situated in the electric components tray under the bonnet.

F1	F2	F3	F4	F5
40A	20A	10A		5A
48V	48V	48V		12V

- F1 40 Amp protects the heating
- F2 20 Amp protects the DC/DC converter
- F3 10 Amp protects the motor turbine, speed controller, main contactor,
- F4 Free
- F5 5 Amp protects the dashboard

**3-** A 250 A fuse protects the traction battery power circuit. It is situated in the electric components tray under the bonnet.

**ATTENTION:** If after replacement the new fuse blows, have your MEGA dealer check the electric circuit.

**4-** A switch to cut the main 48Volt circuit (red tap) situated on the electric components tray is used to isolate the traction batteries from the operating system during maintenance operations.

## SPARE TYRE

The vehicle is equipped with a spare tyre underneath the rear floor, a jack situated in a box within the interior of the spare tyre and a wheel brace clipped to the driver's seat\* base.

### CHANGING A WHEEL

- Park the vehicle on firm flat ground.
- Engage the hand brake and wedge the vehicle wheels.
- Remove the spare wheel from its compartment.
- Remove the jack from its box.

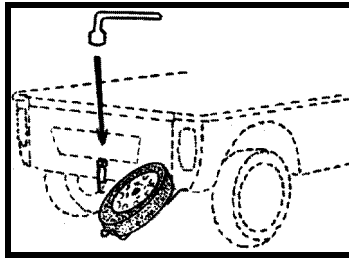

- Loosen the wheel nuts with the wheel brace after removing the hubcap.
- Place the jack under the vehicle in appropriate place for the specific wheel to be changed.
  1. jack position for changing rear wheel
  2. jack position for changing front wheel

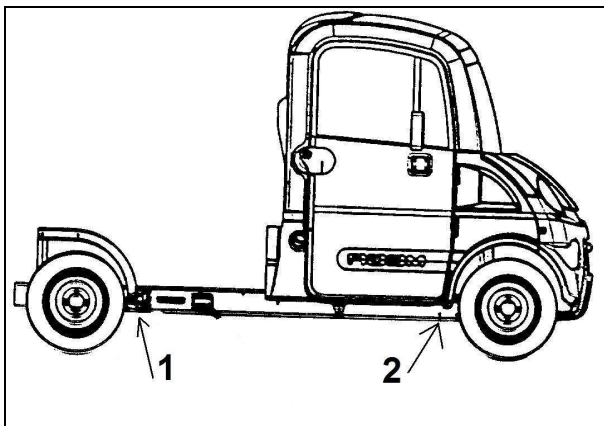

## **SPARE TYRE (continued)**

- Raise the vehicle by turning the jack handle.
- Remove the nuts.
- Remove the wheel.
- Put on the spare wheel, replace and tighten nuts firmly before lowering the vehicle.
- Recheck wheel nut torque.
- Replace the hubcap.
- Store and secure the flat tyre in the spare tyre compartment.
- Repair the flat tyre, making sure to check the air pressure is correct and then as soon as possible, replace the spare wheel on the vehicle.

## **REPLACING A HEADLAMP BULB**

### **REPLACING A MAIN BEAM LIGHT BULB**

- In order to have access, pass the hand under the dashboard, remove the waterproofing cover, and pull on the light bulb .Replace bulb

### **REPLACE THE DIPPED BEAM HEADLAMP BULB**

- Proceed in the same way as described above and unclip the bulb holder that is situated behind the headlamp glass. Replace light bulb.

### **REPLACING THE FRONT INDICATOR LIGHT BULB**

- In order to gain access, pass the hand under the wheel arch, turn the left side lamp holder and take it out. Replace bulb.

### **REPLACING THE REAR LIGHTS**

- Using a screwdriver, unscrew the two screws in the transparent section of the rear lamp. Replace one or more bulbs.

### **REPLACING AN INTERIEUR LIGHT BULB**

- Unclip the light from its support to replace bulb.

# CHECKING LEVELS

Diesel versions

## ENGINE OIL

All engines consume a small quantity of oil. It is therefore important to check the level of oil at regular intervals or before a long journey. Perform the check with the engine warm and the vehicle stationary. Park the vehicle on a flat surface and stop the engine. Wait a few moments to allow the oil to settle, in order to give a true and exact measurement of the oil.

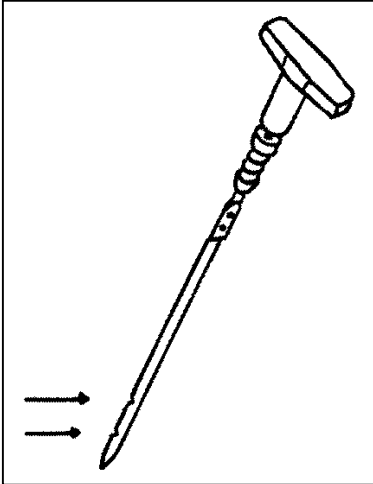

## CHECKING THE ENGINE OIL LEVEL

In order to check the engine oil level you must first open the bonnet. Remove the dipstick and wipe with a clean cloth. Replace the dipstick. Remove again and read the measurement of the quantity of engine oil that appears between the two marks.

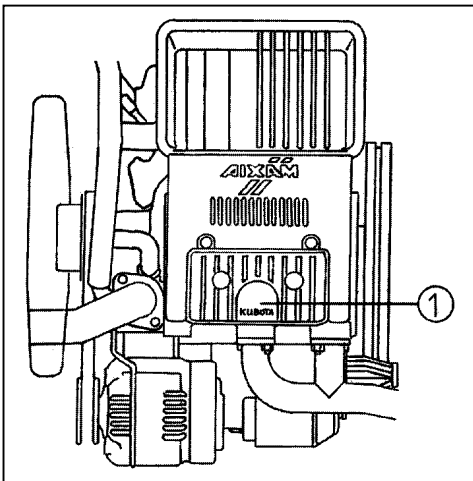

If the level of oil is less than the maximum limit, remove the oil cap (1) and add oil. It is important to use the correct specification. Ensure that the oil cap is correctly secured in place.

## CHECKING LEVELS

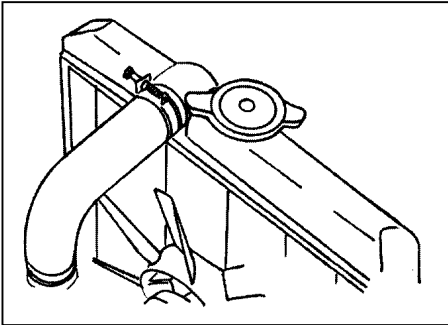

### CHECKING THE COOLING FLUID LEVEL

- to control the level of cooling fluid open the bonnet
- This check should be carried out with the engine cold in order to avoid the risk of burning.
- To check, remove the radiator cap.

The cooling fluid level should reach the upper radiator grill level.

Add fluid if necessary

Replace and ensure that radiator cap is fitted securely

NB: It is advised to replace the cooling fluid every year.

### CHECKING TRANSMISSION OIL LEVEL (diesel vehicles)

- Raise the vehicle.
- Remove the level screw (3). For a correct level of oil, the oil should be level with the sight hole.
- Fill up if necessary. Unlock and remove the filling cap (4).
- Always fill to the precise level indicated. An excess of oil leads to leakage.

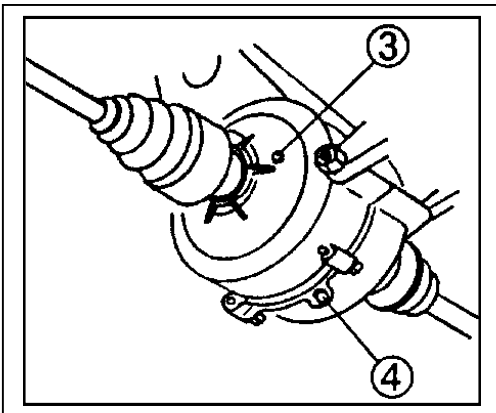

## **CHECKING REDUCTION UNIT OIL LEVEL (electric vehicles)**

- Raise the vehicle.
- Remove the level screw (2). For a correct level of oil, the oil should be level with the sight hole.
- Fill up if necessary. Unlock and remove the filling cap (1).
- Always fill to the precise level indicated. An excess of oil leads to leakage.

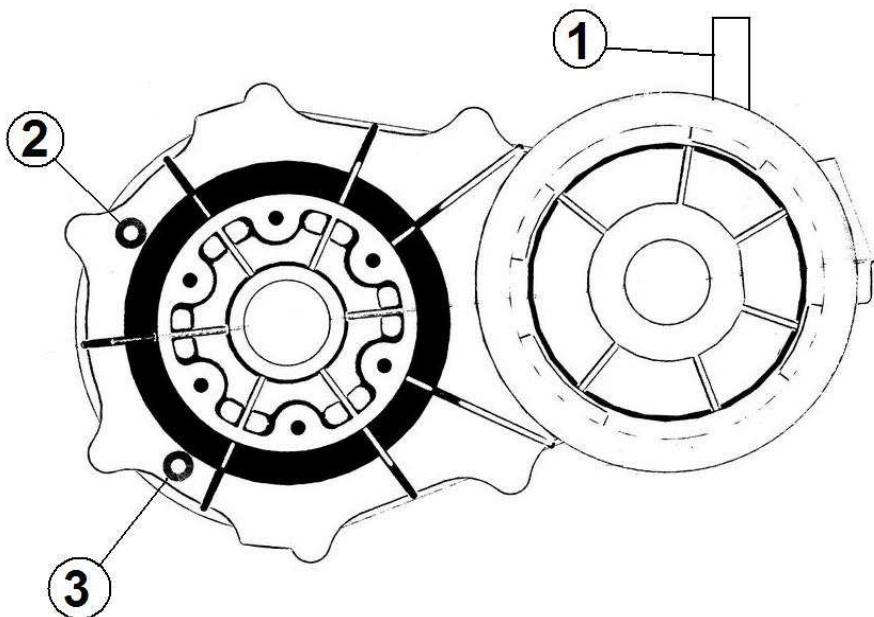

- (1) – Filling cap
- (2) – Level screw
- (3) - Oil change screw

## CHECKING THE BRAKE FLUIDS LEVEL

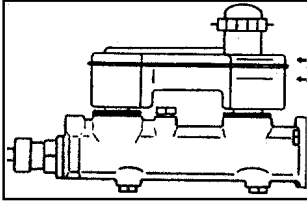

### Brake fluid level.

The level should be between the two marks  
Add brake fluid if necessary

NB: It is advised that the brake fluid is replaced every year.

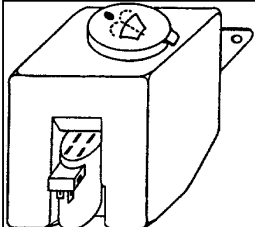

### Windscreen wash liquid

Add windscreen wash liquid when necessary. Do not use alcohol based products.

## TYRE PRESSURE

The tyres should be checked at regular intervals to ensure that they are not cracked or worn.



### PRESSURE AND INFLATING OF TYRES (BAR)

#### **Diesel versions**

	Tyres	Front	Rear	Spare
145/70 R13	With no load	2,0	2,0	2,4
	When loaded	2,0	2,4	2,4

#### **Versions électriques**

	Tyres	Front	Rear	Spare
145/70 R13	With no load	2,0	2,4	2,4
	When loaded	2,0	2,4	2,4

## DESCRIPTION OF TIPPER

1. Aluminium Tipper floor
2. Tipper chassis
3. Front fixed panel
4. Lock for side and rear panels
5. Side panels
6. Side panel hinge
7. Hydraulic pump reservoir
8. Hydraulic hose
9. Hydraulic pump
10. Hydraulic Ram
11. Lower Tipper chassis

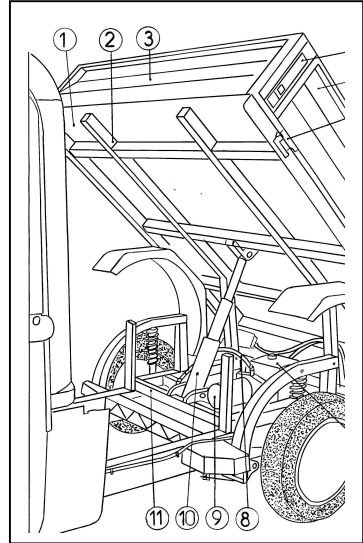

The polyester pickup platform is not shown on drawings



**Never place objects (tools etc) under the tipper body during the period for which the vehicle will be moving, as they may damage the electrical, mechanical or hydraulic components.**

# **NECESSARY PRECAUTIONS WHILST LOADING**

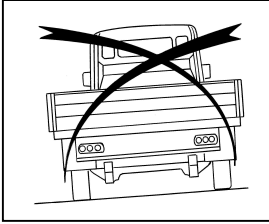

The vehicle must be stationary and on level ground, whilst being loaded. If not there is a risk of the vehicle turning over or getting bogged down.

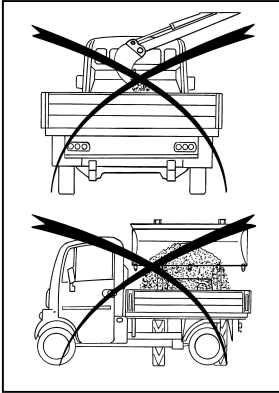

It is forbidden to load the vehicle using large machines used for road building (diggers etc...).

The floor of the tipper body being made of aluminium in order to improve the payload, would not be able to support objects being released from such machines.

The load must be in compliance with the payload as well as the weight distribution authorised per axle. The weight of the load must be centred on the tipper and must not exceed the height of the side panels.

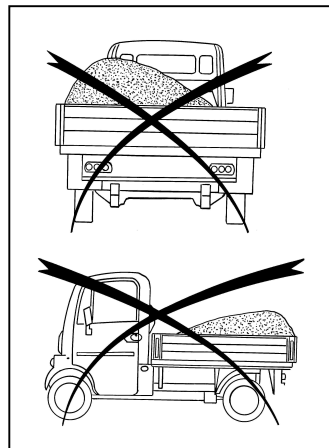
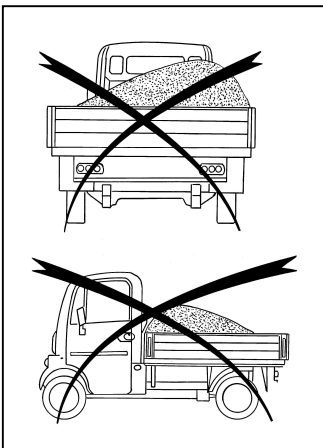

## **NECESSARY PRECAUTIONS WHILST DRIVING**

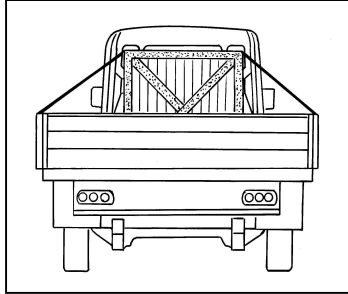

Whilst driving on the road the tipper must be in its lowered position, otherwise there is a risk of tipping over.

The goods that are transported in the tipper must be secured and must not exceed the height of the side panels.

For the transport of leaves or grass cuttings, branches, or general litter, a net (optional extra) should be used to retain the items in the tipper body.

### **CENTRE OF GRAVITY OF THE LOAD**

When transporting an object whose centre of gravity is off centre or very high, always place it so that the centre of gravity is as close to the tipper floor as possible, in order not to destabilise the vehicle.

When the vehicle is carrying a load always drive safely and keep a safe distance from the vehicle in front. Whilst travelling downhill use as much as possible the engine brake as well as the mechanical brakes in order to avoid the freewheeling of the vehicle.

Never drive with the tailgate lowered as this obstructs the rear lights. The same applies to the side panels as they would not be secured and could cause damage if they swing out whilst the vehicle is moving.

Always ensure that the load does not exceed the length of the tipper body so as not to obstruct the rear lights or have the risk of causing injury to third parties.

## **NECESSARY PRECAUTIONS WHILST UNLOADING**

Before raising the tipper body always open the rear tailgate. If this is not done the objects loaded in the vehicle would accumulate against the tailgate and could damage it beyond repair.

**ADVISE:** When lowering the side panels we advise that you take care to avoid slamming the side panels against the side of the vehicle as this may damage the vehicle.

If you wish to remove a side panel, lower to the horizontal position and slide sideways. Always store in a safe place where it cannot be driven over by the vehicle.

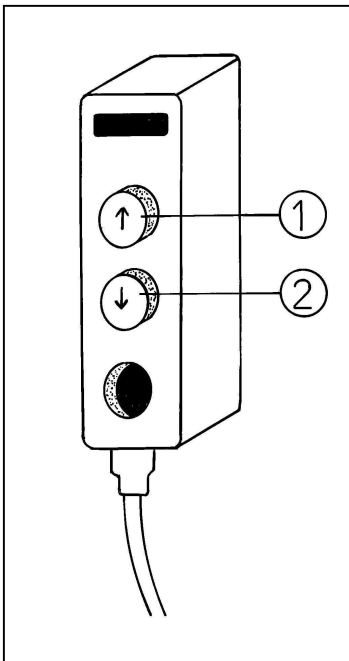

In order to unload the tipper, press the button 1 on the remote control, this will cause the tipper to raise.

When unloaded press the button 2 on the remote and the tipper body will lower.

**NOTE:** It is possible during the first uses of the tipper that the body does not lower completely. In this case it is necessary to press lightly on the tipper at the same time as pressing the button 2 on the remote control.. This incident only occurs during the "running in" period of the body.

**Once the tipper body has been lowered do not forget to secure the rear tailgate panel.**

## FAULT FINDING

FAULT	CAUSES	SOLUTIONS
<p>The tipper doesn't rise and the hydraulics don't make any noise.</p>	<p>12 volt batteries are discharged Broken fuse Remote not working Pump starter relay not working</p>	<p>Check batteries Check battery charge circuit Replace fuse Check electrical wiring circuit Check remote Repair or replace remote</p>
<p>The tipper body doesn't rise but the hydraulics seems to be working.</p>	<p>Too much weight in skip Lack of hydraulic fluid in the reservoir Damaged link between motor and pump Hydraulic hose blocked or leaking Ram leaking</p>	<p>Check battery Ensure load is suitable for vehicle Add hydraulic fluid Check for leaks in hydraulic circuit Replace hydraulic pump Replace flexible hose Replace ram</p>
<p>The tipper body only rises partially.</p>	<p>Insufficient fluid level An obstacle is preventing the tipper action.</p>	<p>Add hydraulic fluid Faire l'appoint d'huile Ensure all necessary safety precautions are taken</p>

## FAULT FINDING

71

INCIDENTS	CAUSES	
The tipper body doesn't rise	Remote not working Hydraulic hose blocked Damaged valve coil Damaged electrovalve	Repair or replace the remote Replace the hydraulic hose Replace coil Replace the electrovalve
The tipper body does not go down completely	New ram. During wearing in period it is possible that the ram does not retract completely.	Raise the tipper and then lower assisting manually ensuring all necessary safety precautions are taken
The tipper body rises alone	Remote problem Short circuit	Repair or replace the remote Check electrical wiring circuit
The tipper action does not stop when the remote button is released.	Damaged electrovalve	Replace electrovalve
The warning beeper is not working	Warning beeper not working Electric connection or wiring problem.	Replace warning beeper Repair

## MAINTENANCE

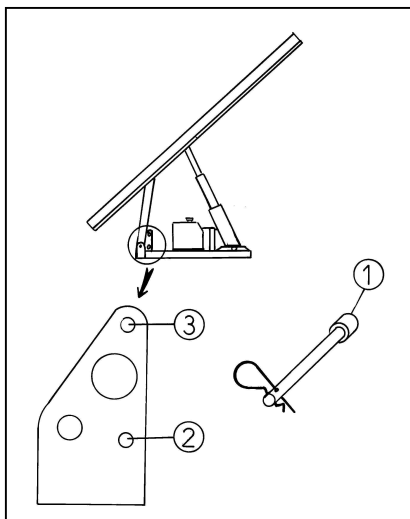

Before any maintenance operation or repair under the tipper body, raise the tipper to its maximum height and lock it in place by using the small safety pin that has been supplied.

Take out the Pin 1 from its housing 2, raise the tipper to its maximum height and insert the pin into the hole 3

For any operation the tipper must first be emptied, as the mechanical support has only been designed to support the weight of the tipper body in its empty state.

Then disconnect the battery so that no-one can activate the tipper and injure the operator who may be underneath. After the maintenance operation, ensure that the support pin 1 is replaced in hole 2.

# MAINTENANCE

## HYDRAULIC FLUID

The replacement of the hydraulic fluid should be carried out every 4 years.

Fluid type: HV46 hydraulic

Quantity 4 litres

With the tipper raised the fluid should reach the minimum graduation mark on the tank.

## GREASING

We advise that the two moving arms are greased at regular intervals, as well as the moving parts on the upper section of the ram. These moving parts are equipped with nipples ①.

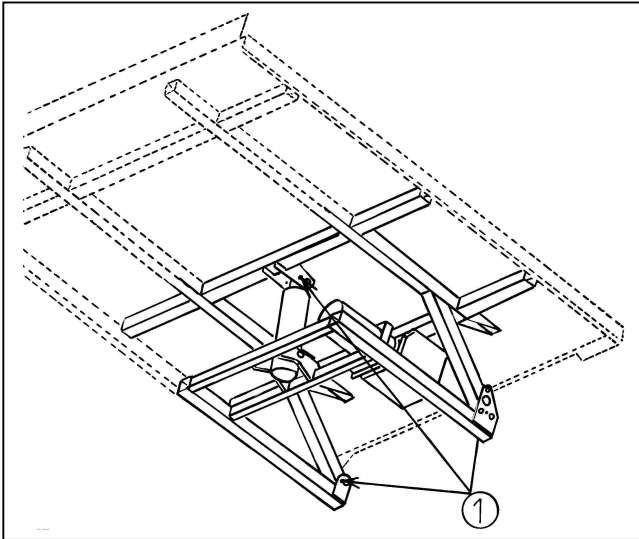

## CLEANLINESS

We advise that the tipper mechanism is checked on a regular basis. In order for these checks to be effective we advise that all the mechanical, electrical, and hydraulic components be cleaned. Any small defects may become apparent at this time and can be rectified quickly before more serious issues arise.

## REMINDER OF ADHESIVE SIGNIFICATION

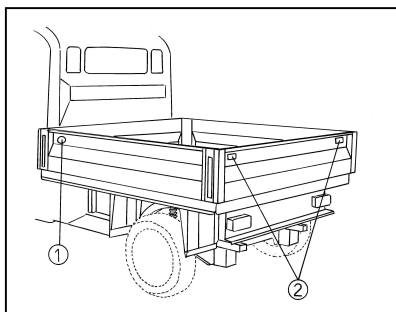

Stickers have been put on the tipper body in order to bring the safety issues to the attention of the operator during the use of the vehicle.

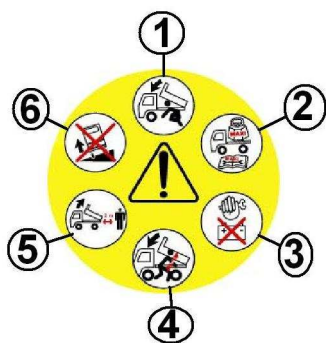

1. When raising or lowering the tipper body, ensure that there is no-one underneath.
2. Always ensure that the weight limits are not exceeded
3. Before any maintenance operation always ensure that the 12V battery is disconnected.
4. When raising or lowering the tipper body always ensure that nothing is obstructing the movement.
5. When emptying the contents of the tipper always ensure that there is no-one within a perimeter of 2 metres of the vehicle.
6. Never raise the tipper body if the vehicle is parked on unstable or unlevel ground.



It is necessary to open the rear tailgate panel in order to empty the contents. There is a risk of irreparable damage if this instruction is not adhered to.

# SKIP TIPPER SPECIFICATIONS

- 1- Tipper
- 2- Ram
- 3- chassis
- 4- Electric valve
- 5- Safety locks
- 6- Pump

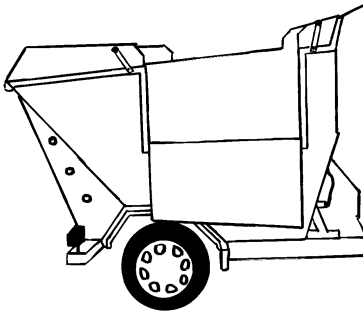
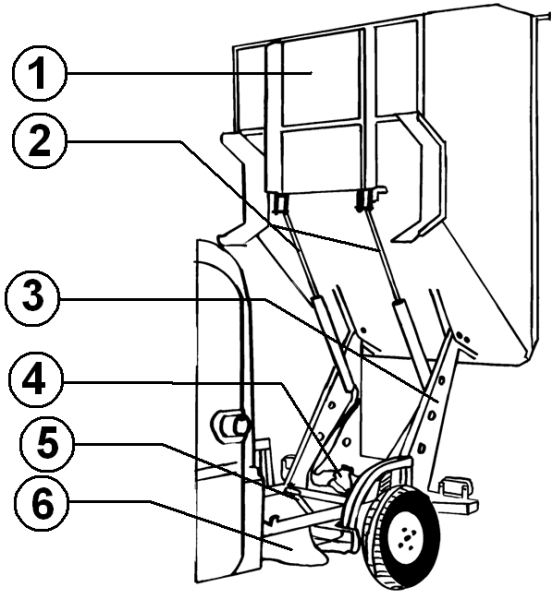

The Skip Tipper is equipped with a side door in order to facilitate the loading of the body.



Never place objects (tools etc) under the tipper body during the period for which the vehicle will be moving, as they may damage the electrical, mechanical or hydraulic components.

## NECESSARY PRECAUTIONS WHILST LOADING

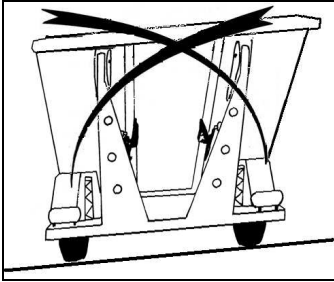

The vehicle must be stationary and on level ground, whilst being loaded. If not there is a risk of the vehicle turning over or getting bogged down.

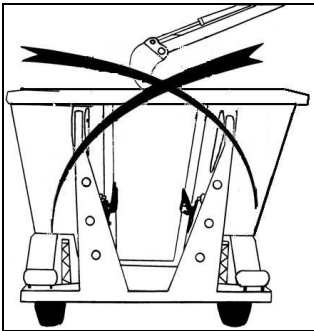

It is forbidden to load the vehicle using large machines used for road building (diggers etc...).

The floor of the tipper body being made of aluminium in order to improve the payload, would not be able to support objects being released from such machines.

The load must be in compliance with the payload as well as the weight distribution authorised per axle. The weight of the load must be centred on the tipper and must not exceed the height of the side panels.

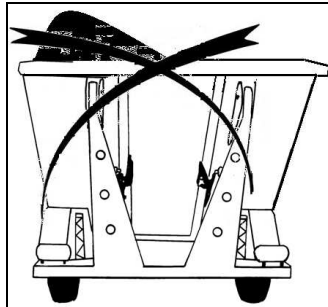
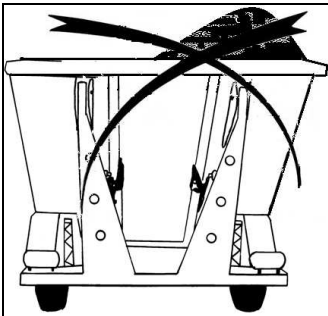

# NECESSARY PRECAUTIONS WHILST UNLOADING

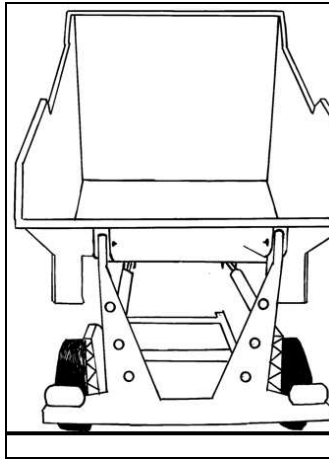

In order to unload the tipper, press the button 1 on the remote control, This will cause the tipper to raise.  
When unloaded press the button 2 on the remote and the tipper body will lower.

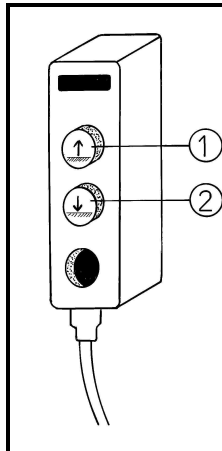

## FAULT FINDING

FAULT	CAUSES	SOLUTIONS
<p>The tipper doesn't rise and the hydraulics don't make any noise.</p>	<p>12 volt batteries are discharged Broken fuse Remote not working Pump starter relay not working</p>	<p>Check batteries Check battery charge circuit Replace fuse Check electrical wiring circuit Check remote Repair or replace remote</p>
<p>The tipper body doesn't rise but the hydraulics seems to be working.</p>	<p>Too much weight in skip Lack of hydraulic fluid in the reservoir Damaged link between motor and pump Hydraulic hose blocked or leaking Ram leaking</p>	<p>Check battery Ensure load is suitable for vehicle Add hydraulic fluid Check for leaks in hydraulic circuit Replace hydraulic pump Replace flexible hose Replace ram</p>
<p>The tipper body only rises partially.</p>	<p>Insufficient fluid level An obstacle is preventing the tipper action.</p>	<p>Add hydraulic fluid Faire l'appoint d'huile Ensure all necessary safety precautions are taken</p>

## FAULT FINDING

INCIDENTS	CAUSES	SOLUTIONS
The tipper body doesn't rise	Remote not working Hydraulic hose blocked Damaged valve coil Damaged electrovalve	Repair or replace the remote Replace the hydraulic hose Replace coil Replace the electrovalve
The tipper body does not go down completely	New ram. During wearing in period it is possible that the ram does not retract completely.	Raise the tipper and then lower assisting manually ensuring all necessary safety precautions are taken
The tipper body rises alone	Remote problem Short circuit	Repair or replace the remote Check electrical wiring circuit
The tipper action does not stop when the remote button is released.	Damaged electrovalve	Replace electrovalve
The warning beeper is not working	Warning beeper not working Electric connection or wiring problem.	Replace warning beeper Repair

## **SAFETY MEASURES TO TAKE INTO ACCOUNT WHEN CARRYING OUT MAINTENANCE.**

Before carrying out any maintenance or repair under the skip tipper body, raise it to its maximum height and put in place the safety stand. Unscrew the stand 1 and lodge in the housing 2. Lower the tipper body in order that the tipper rests on the stand.

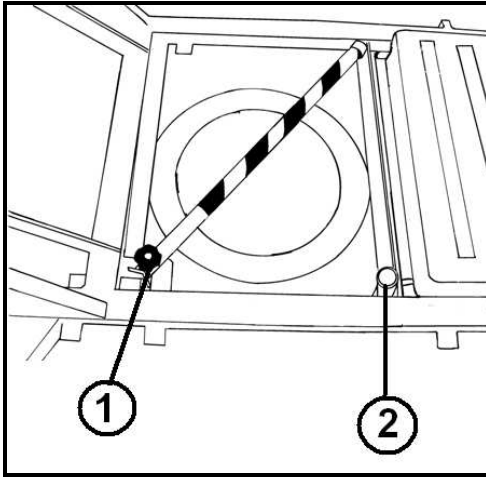

For these operations, it is absolutely necessary for the tipper to be empty, as the mechanical support system has been designed to take the weight of an empty tipper.

Then disconnect the battery so that no-one can activate the tipper and risk injuring the operator working under the vehicle.

After completing the maintenance work do not forget to reposition the safety stand.

# MAINTENANCE

## HYDRAULIC FLUID

The replacement of the hydraulic fluid should be carried out every 4 years.

Fluid type: HV46 hydraulic

Quantity 4 litres

With the tipper raised the fluid should reach the minimum graduation mark on the tank.

## GREASING

We advise that the two moving arms are greased at regular intervals, as well as the moving parts on the upper section of the ram. These moving parts are equipped with nipples  $\text{\textcircled{O}}$ .

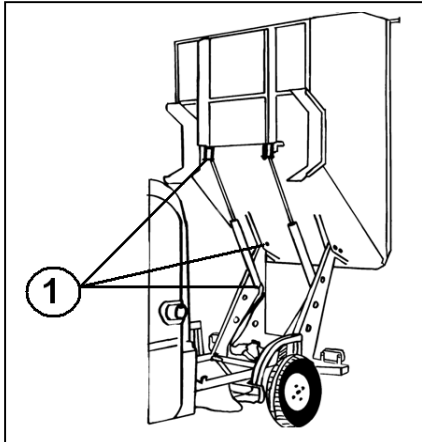

## CLEANLINESS

We advise that the tipper mechanism is checked on a regular basis. In order for these checks to be effective we advise that all the mechanical, electrical, and hydraulic components be cleaned. Any small defects may become apparent at this time and can be rectified quickly before more serious issues arise.

# REMINDER OF ADHESIVES SIGNIFICATION

Stickers have been put on the tipper body in order to bring the safety issues to the attention of the operator during the use of the vehicle.

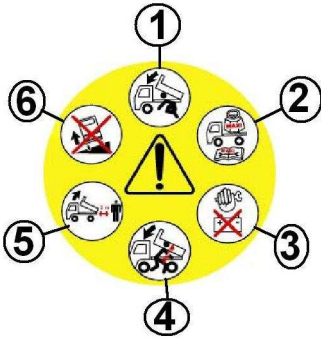

1. When raising or lowering the tipper body, ensure that there is no-one underneath.

2. Always ensure that the weight limits are not exceeded

3. Before any maintenance operation always ensure that the 12V battery is disconnected.
4. When raising or lowering the tipper body always ensure that nothing is obstructing the movement.
5. When emptying the contents of the tipper always ensure that there is no-one within a perimeter of 2 metres of the vehicle.
6. Never raise the tipper body if the vehicle is parked on unstable or unlevel ground.

## ASSISTANCE AND TOWING

If the vehicle is immobilised following an accident or a breakdown, it is forbidden to tow the vehicle. (The risk of damaging mechanical components is great).

Your vehicle should be loaded onto a trailer.

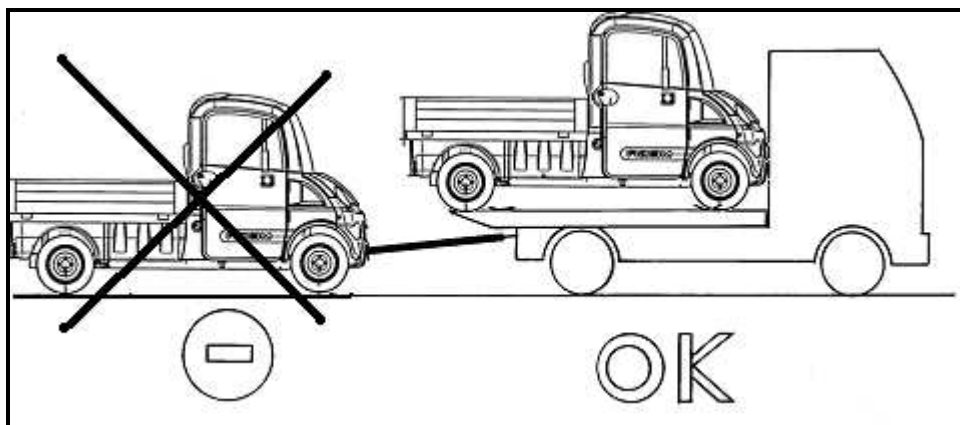

## VEHICLE IDENTIFICATION

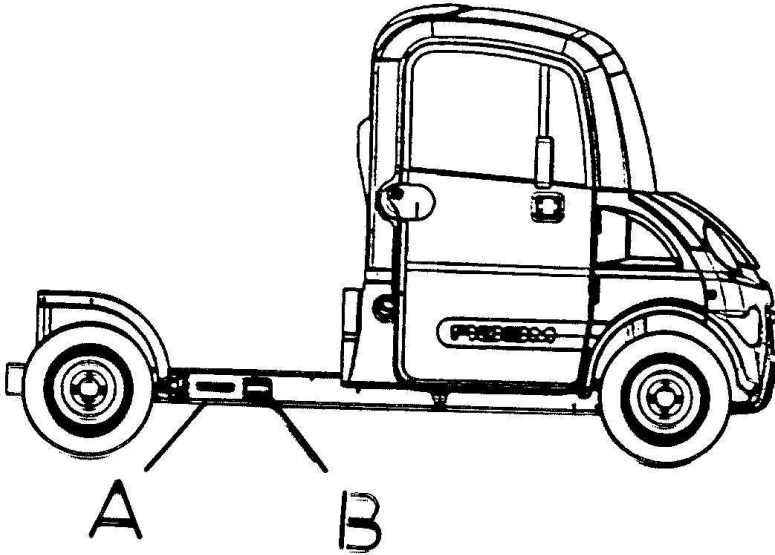

A- The serial number is cold stamped under the vehicle on the right hand chassis strut

B- The manufacturers plate is riveted on the right hand side chassis strut next to the stamped serial number.

## NOTES

A series of 20 horizontal dotted lines for writing notes.

## NOTES

A series of 20 horizontal dotted lines for writing notes.

## NOTES

A series of 20 horizontal dotted lines for writing notes.

## NOTES

A series of 20 horizontal dotted lines for writing notes.

*The information given in this document relates only to commercial vehicles in Europe, with a L6e or L7e quadricycles homologation.*

*MEGA reserves the right to modify without notification any technical characteristics and equipment, without updating this document.*



**AIXAM MEGA**

56, route de Pugny – BP 112  
73101 AIX LES BAINS cedex – France  
Tél. 33 (0) 4.79.61.42.45 – Fax 33 (0) 4.79.35.06.11

[www.mega-vehicles.com](http://www.mega-vehicles.com)