

USER MANUAL

FOR INSTALLATION, OPERATION
AND MAINTENANCE
OF TRIPLE PARKING STACKER

Applicable Model

HP2525, HP2625

Read this entire manual before
installation or operation!



CATALOG

1. Safety instructions	01
2. Product overview	01
3. Site planning	04
4. Installation	07
5. Hydraulic & Electrical Diagrams	24
6. Operation	28
7. Surface Cleaning & Protection	29
8. Maintenance	30
9. Troubleshooting	32

1 Safety instructions

Please read the entire contents of this manual prior to installation and operation. By proceeding you agree that you fully understand and comprehend the full contents of this manual. Forward this manual to all operator. Failure to operate this equipment as directed may cause injury or death.

1.1. Copyright. Copyright by Mutrade Industrial Corp. All rights reserved. You are not allowed to use the copies for commercial purposes.

1.2. Usage. Hydro-Park 2525 series parking stackers (hereinafter HP2525) are designed for stacking 3 vehicles on top of each other for permanent parking or car storage, any other usages are to be considered improper, thus highly forbidden.

1.3. Receiving. When receiving the cargos, please check the packaging carefully and thoroughly. Contact sales person of Mutrade to verify the causes for any shortages or damages. Claims for material damage shall be made against the transportation company.

1.4. Warranty. Every new lift enjoys 5 years warranty on the main structure and one year warranty on parts and accessories. For detailed warranty policy, please click here to download the specific PDF file. 

1.5. Installer. Only trained installers with basic automotive lift installation experiences are allowed to install this lift. Do not attempt to lift any structural parts without reliable lifting tools such as chain blocks, forklifts or cranes, etc.

1.6. Protection. Installers shall be equipped with necessary personal protective equipment such as durable work clothing, tight-fitting gloves, sturdy shoes, safety glasses or goggles, etc.

1.7. Caution. Keep your hands and feet away from any moving parts.

1.8. Electrical. The electrical services must be carried out by certified electricians conforming to local codes, regulations, or any other applicable codes.

1.9. Owner. Owners shall make sure that all operators have been properly trained, knowing how to safely and correctly operate the system.

1.10. Modify. Do not modify this parking lift or use any part which is not from the manufacturer.

1.11. Danger. It's FORBIDDEN for any person to stay on the platform when the equipment is operating.

1.12. Warning. Do not operate or repair this equipment without reading this manual and the safety instructions inside thoroughly.

1.13. Maintenance. This product requires regular inspection and proper maintenance.

1.14. ⚠ This mark means safety warning.

1.15. Liability. Manufacturer shall assume no liability for loss or damage of any kind, expressed or implied resulting from improper installation or use this product.

2 Product overview

2.1. Introduction

HP2525 series are newly-developed triple stackers for permanent parking or car storage. The platforms move only vertically and are driven by a hidden hydraulic cylinder with ropes beneath the lower platform.

Multiple designs of commercial grade are adopted to offer most reliable using experience, including emergency stop, mechanical anti-falling locks, auto lock release, and many other electrical protections etc.

This series contains two models:

HP2525: Each system offers 3 parking spaces, ground and lower platform spaces are for SUVs, capacity 2500kg (5512lbs), upper platform shall be reserved for sedans only whose weight < 2000kg (4400lbs). Required headroom including sedan on top is 6046mm (19.84ft).

HP2625: a shorter version of HP2525, suitable for one medium SUV on ground, and another 2 sedans on lower & upper platforms. Required ceiling height is 5294mm (19.37ft) only.

2.2. General parts



- | | |
|----|-----------------------------------|
| 1 | Main post. |
| 2 | Front right post & rear left post |
| 3 | Rear right post. |
| 4 | Runways of lower platform |
| 5 | Cover plates on lower platform |
| 6 | Hydraulic cylinder |
| 7 | Power pack & electrical box |
| 8 | Operating panel (Key switch) |
| 9 | Crossbeam of lower platform |
| 10 | Runway of upper platform |
| 11 | Cover plates on upper platform |
| 12 | Cover plates of posts |
| 13 | Side beams |
| 14 | Anti-falling hook |
| 15 | Ramp |
| 16 | Wheel stopper |

(1) Parts

Note: the front side of lift is the ramps, front view.

2.3. Dimensions

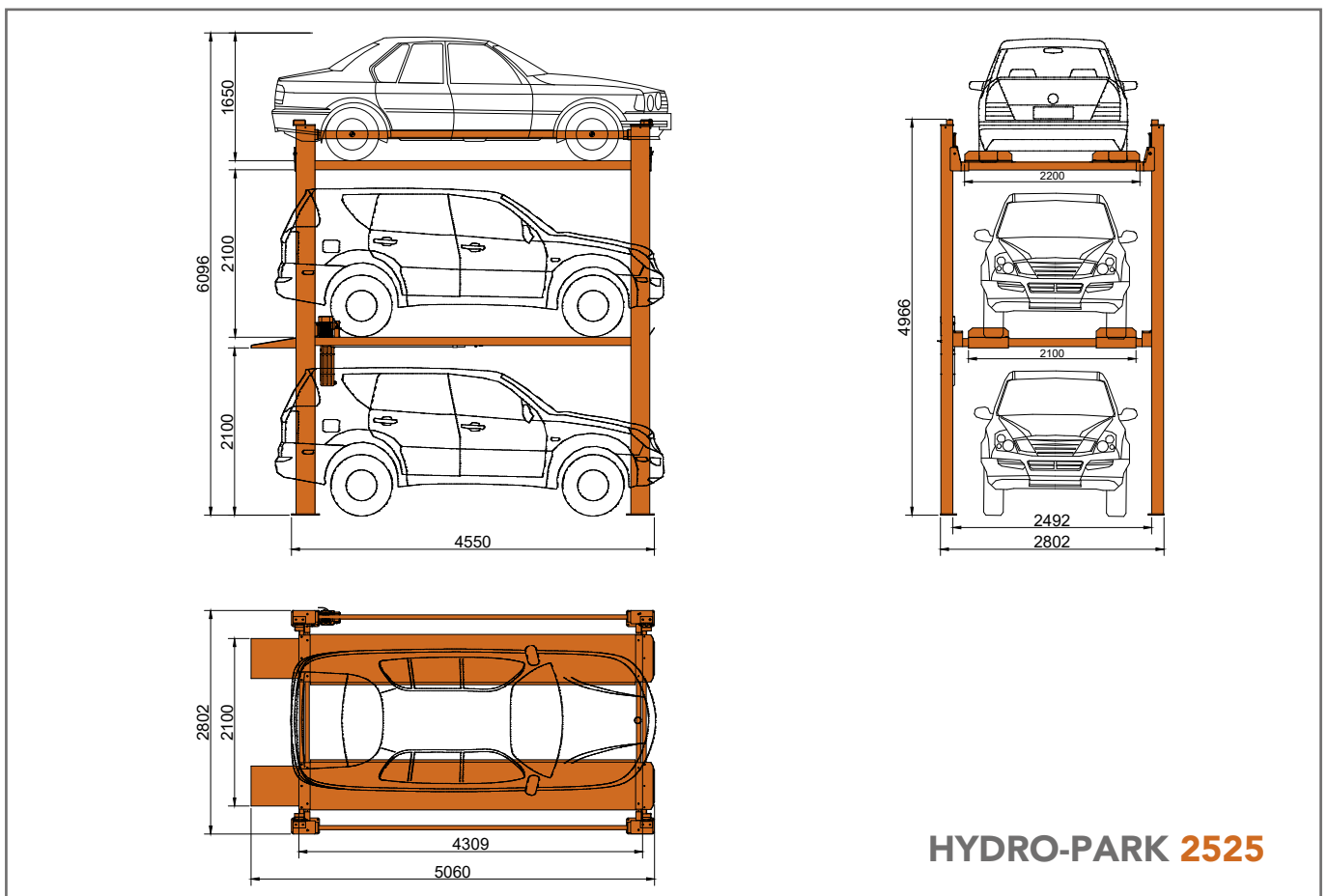
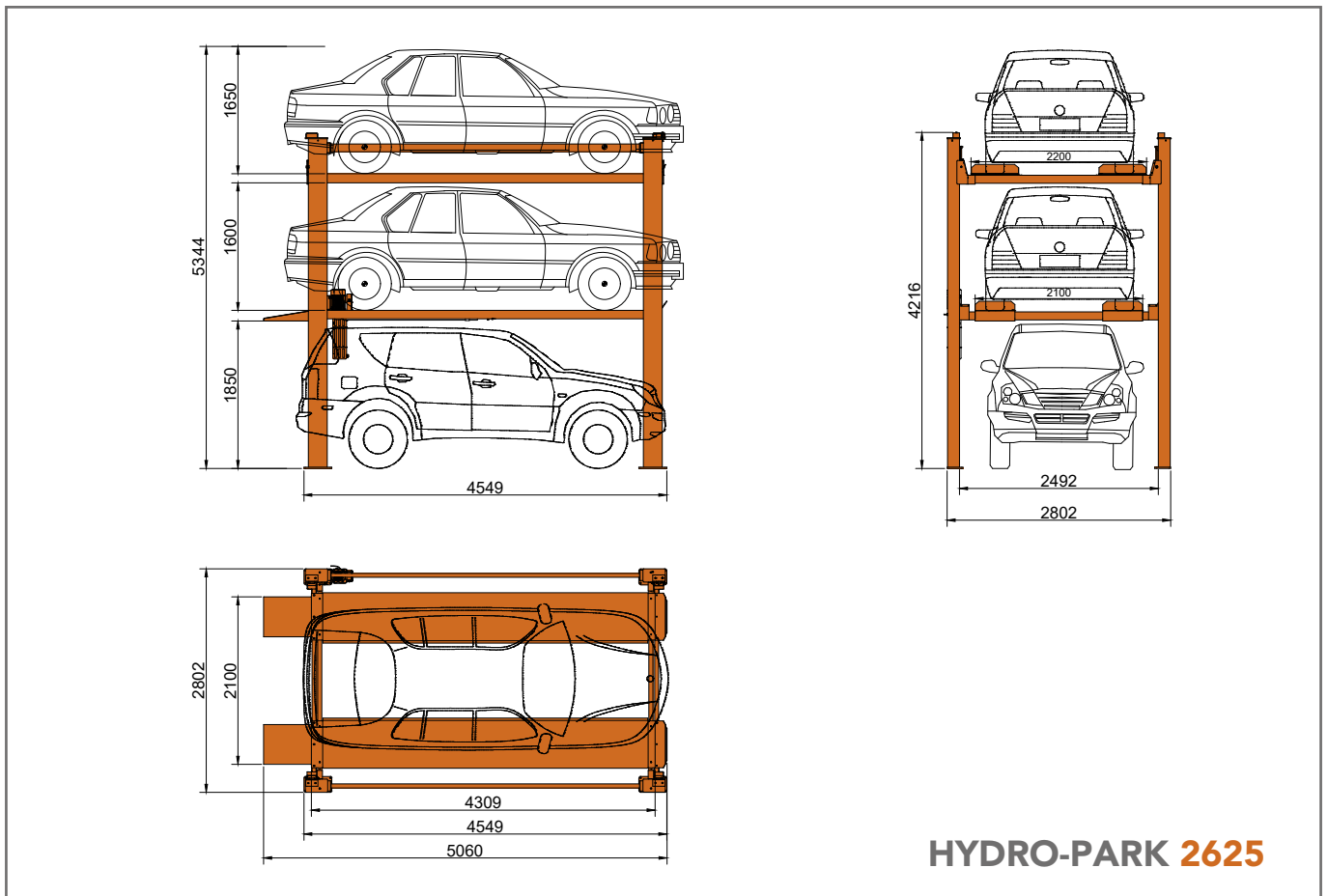

Note: The dimensions may be different as per customer's special requirement. Please contact our Sales for as-produced dimensions.

2.4. Operating conditions

Generally, this parking lift must be installed and operated under the following conditions:

- Voltage supply: 0.9 – 1.1 times of nominal supply voltage as stipulated on sales contract, proforma invoice, or purchase order.
- Frequency: 0.99 – 1.01 times of nominal frequency
- Ambient temperature: -15 °C to +40 °C
- Relative humidity: not exceed 50% at 40 °C
- Atmosphere: Free from excessive dust, acid fume, corrosive gases and salt.
- Avoid exposing to direct sunlight or heat rays which can change the environmental temperature.
- Avoid exposing to abnormal vibration.
- Electrical parts shall withstand the effects of transportation and storage temperature within a range of -15 °C to 55 °C and for short periods not exceed 24 hours at up to +70 °C .

3 Site planning

3.1 Select location

3.1.1 Before installation, consult the architectural plans for the desired location for installation, make sure that the space can be well occupied for your lift.

3.1.2 Make sure that the site space is enough to cater your lifts, either HP2525 or HP2625. Detailed sizes refer to 2.3. Dimensions.

3.1.3 This parking lift is designed for indoor usage only, enough headroom (overhead clearance) must be considered in the entire cover area. Please mind the obstructions such as HVAC materials, hanging lights, electrical lines, etc., which could cause damage to the vehicles on top.

3.1.4 Side clearances at left and right shall be reserved to at least 50mm (2 inches).

3.1.5 Safe clearances in rear side to the wall behind (if available) shall be at least 200mm (8 inches).

3.1.6 Power source shall be easily accessed to the Powder Pack of your lift(s).

3.1.7 For outdoor or exterior installations, please consult our local partners or Mutrade sales team to verify the possibility or purchase outdoor options/add-ons that're necessary to do so.

3.2 Foundation treatment

3.2.1 When installing the parking lift on existing floor

- The floor must be flat and concrete, allowed degree of slope is 1%
- Minimum thickness is 200mm, concrete grade C30 or above.
- If your concrete floor slope is <1%, please use shims to level the lift.
- If your concrete floor slope is >1%, consider making the floor level or using a different location.
- If floor thickness is <200mm, please consult your architect or structural engineer to calculate the loading force to the floor, ensuring that the floor is strong enough to hold the force. Weight of each HP2525 is approx. 2000kg.

3.2.2 When making a new floor for your lifts:

- Minimum concrete thickness is 150mm, concrete grade C30 or above;
- Concrete beneath columns shall be treated separately, thickness at least 200mm, area 500x500mm.
- Pour concrete over rammed earth as shown in below figure, allowed tolerance for evenness is <10mm

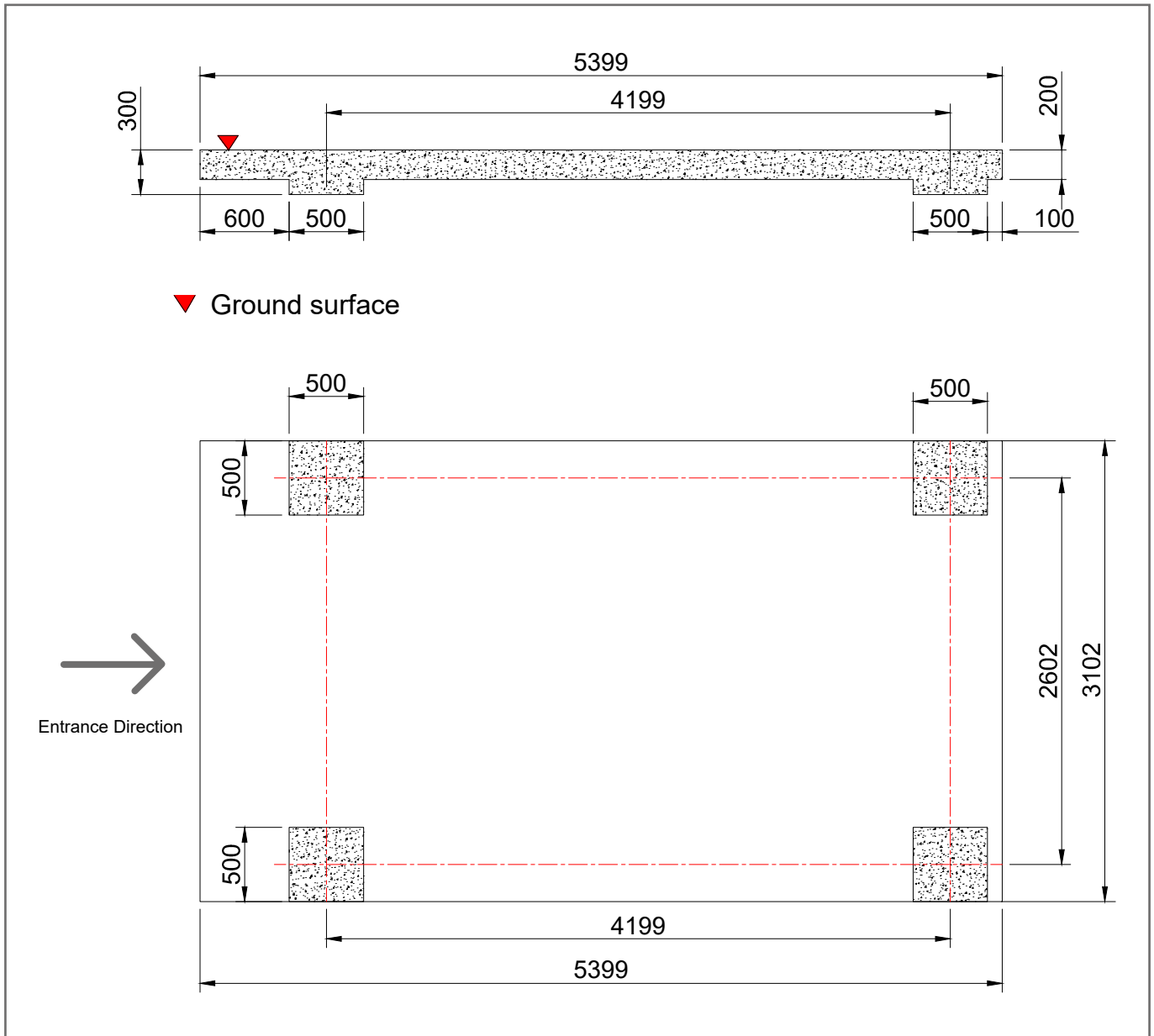

(2) Foundation Diagram

3.2.3 The concrete floor shall be free from any cracks or defects, and should have been dried for at least 28 days.

3.2.4 Pre-embedded anchor bolts are not required.

3.2.5 Keep the working site dry, clean and tidy.

! Foundation concrete with wrong dimensions, poor construction, insufficient concrete thickness or absence of drainage is not allowed to be used for installing parking lift, Mutrade takes no liability for any injuries or losses caused by the above as a consequence.

3.3 Deciding the orientation

Before assembly or installation commenced, you can choose the way of orienting your lift. This will affect where to place the Power Pack and Key Switch (control panel), which are NOT interchangeable.

The left plan in below is the standard configuration, the main post where power pack and key switch mounted is at the entrance side, so that all the works including control, operating, maintenance to power pack are done in front.

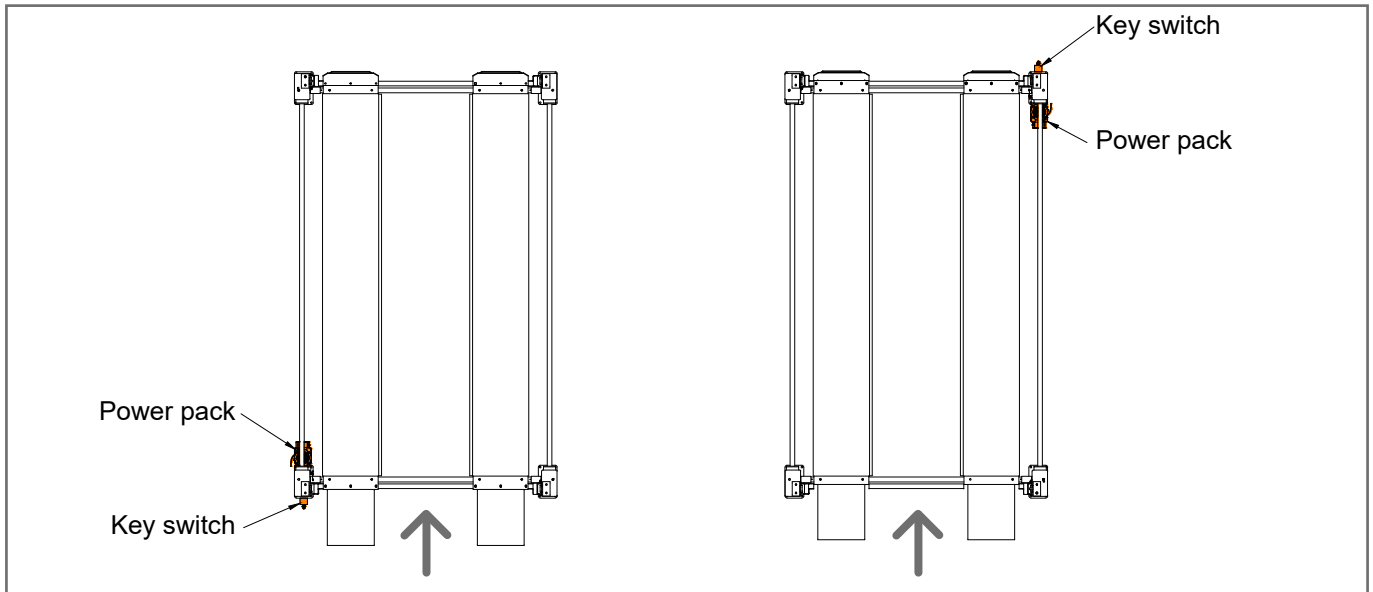

(3) Locations of Power Pack and Key Switch

When you shift the orientation to opposite, the control and other works will be done at the rear side. To do so, please turn the whole structure around, and interchange the ramps and wheel stoppers only.

In some cases, the opposite orientation (right plan) is necessary, especially when the power source is at the rear side and close to the power pack that way. Otherwise, we strongly recommend to install as per the standard way (plan in left).

3.4 Drawing chalk lines

3.4.1 Create chalk lines on the location that's selected as per 3.1 Select Location.

3.4.2 Draw up positions of the baseplates as per the below drawing, tolerance 3mm.

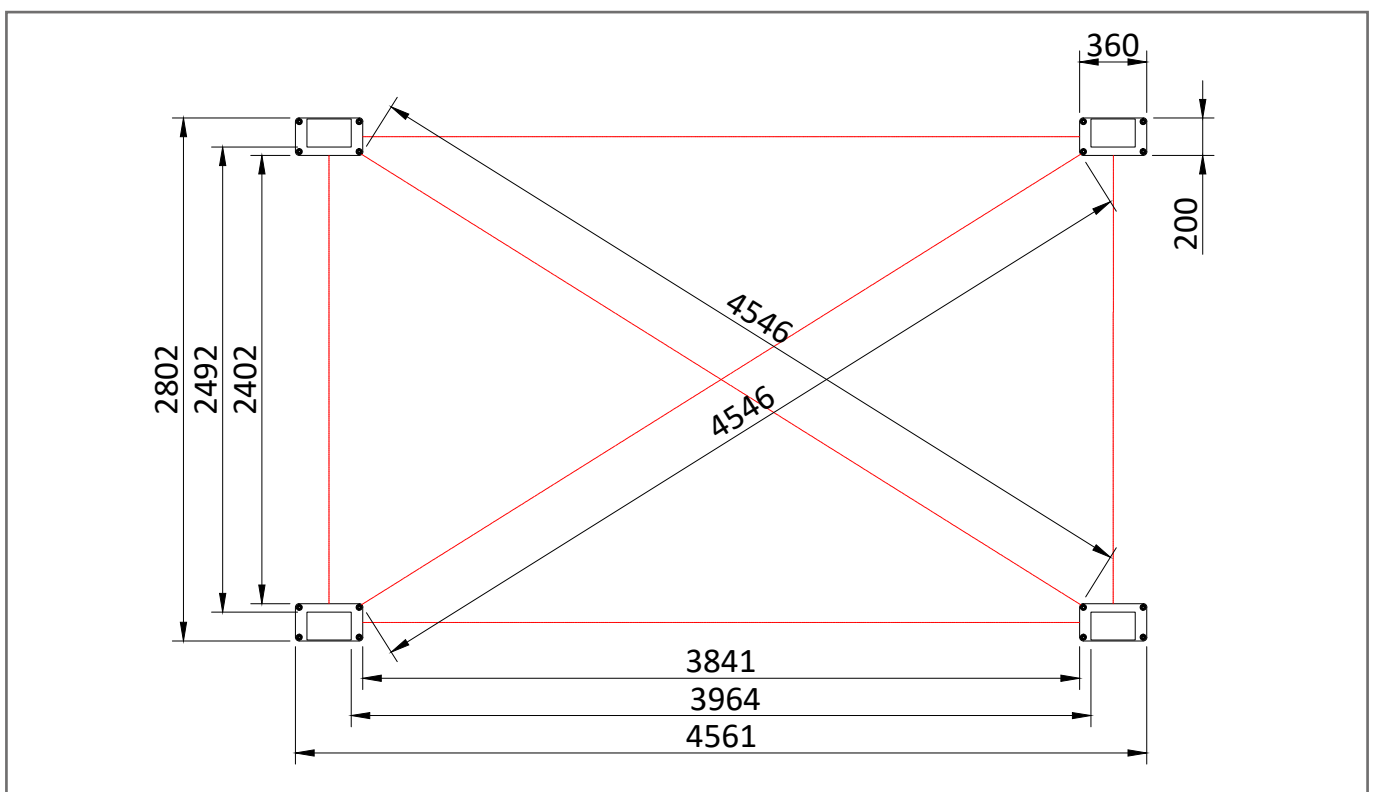

(4) Foundation Dimensions

! For orders and cases with special dimensions, please consult our local partners or Mutrade sales team to get the valid drawing to your order.

3.4.3 Lines shall be parallel or at 90 degrees' angles.

3.4.4 Diagonal distances are of high importance. Please double check the diagonals to the same.

4 Installation

The installation process takes multiple steps, please perform strictly as per the steps here listed. Read the Installation chapter completely and thoroughly before beginning so as to have a better understanding of the whole process.

Only factory-supplied parts that came with your lift shall be used, otherwise you void the warranty and could cause injuries to the installers or operators. If parts are missing, please contact our local partners or Mutrade sales that you originally purchased from. You can also call +86 (532) 5557 9606 or send email to info@qdmtrade.com mentioning the problem that you are experiencing.

4.1 Necessary tools

- | | |
|---|------------------------------|
| ■ 1 set of non-adjustable spanners | ■ Sealing tape |
| ■ 1 set of adjustable spanners | ■ Some power line |
| ■ 1 set of Allen wrench. | ■ 1 piece of hammer |
| ■ 1 set of screwdrivers (both slotted and phillips types) | ■ Some duster cloth |
| ■ Leveling instrument for 1M and 3M. | ■ 1 piece of grease gun |
| ■ 1 unit of forklift with 3T capacity. | ■ 1 piece of tapeline for 5M |
| ■ 1 piece of percussion drilling (12x200 aiguille) | ■ Chalk lines |
| ■ 1 piece of electric portable drill | ■ Two pieces of wood |
| ■ Insulated rubber tape | |

Note: for unloading & goods transportation purposes, 5tons forklift or crane is required.

4.2 Unloading and unpacking

When receiving the cargos, please check the packaging carefully and thoroughly. Contact sales person of Mutrade to verify the causes for any shortages or damages. Claims for material damage shall be made against the transportation company.

Once the goods are signed and unloaded, they are your responsibility to handle. Carefully remove the crating, steel frames or any other packing materials.

Be careful when removing any packing materials as components may loose and fall, causing injuries.

Check the voltage and phase requirements showed on motor or carton of power pack.

Structural parts could be very heavy, forklifts or cranes shall be used to move them into position.

4.3 Assembly

! Usage and connection of all bolts, nuts & washer shall be referred to 4.5 Parts drawings.

4.3.1 Move the posts into position.

Move the 4 posts into position according to the orientation of your lift. The main post is different from other posts since it has the base plate to mount power pack and electric box.

Post #1 is the main post, which has the same structure with #3, except that #1 has the base plate to mount power pack and electric box.

The rest 2 posts are exactly same and interchangeable.

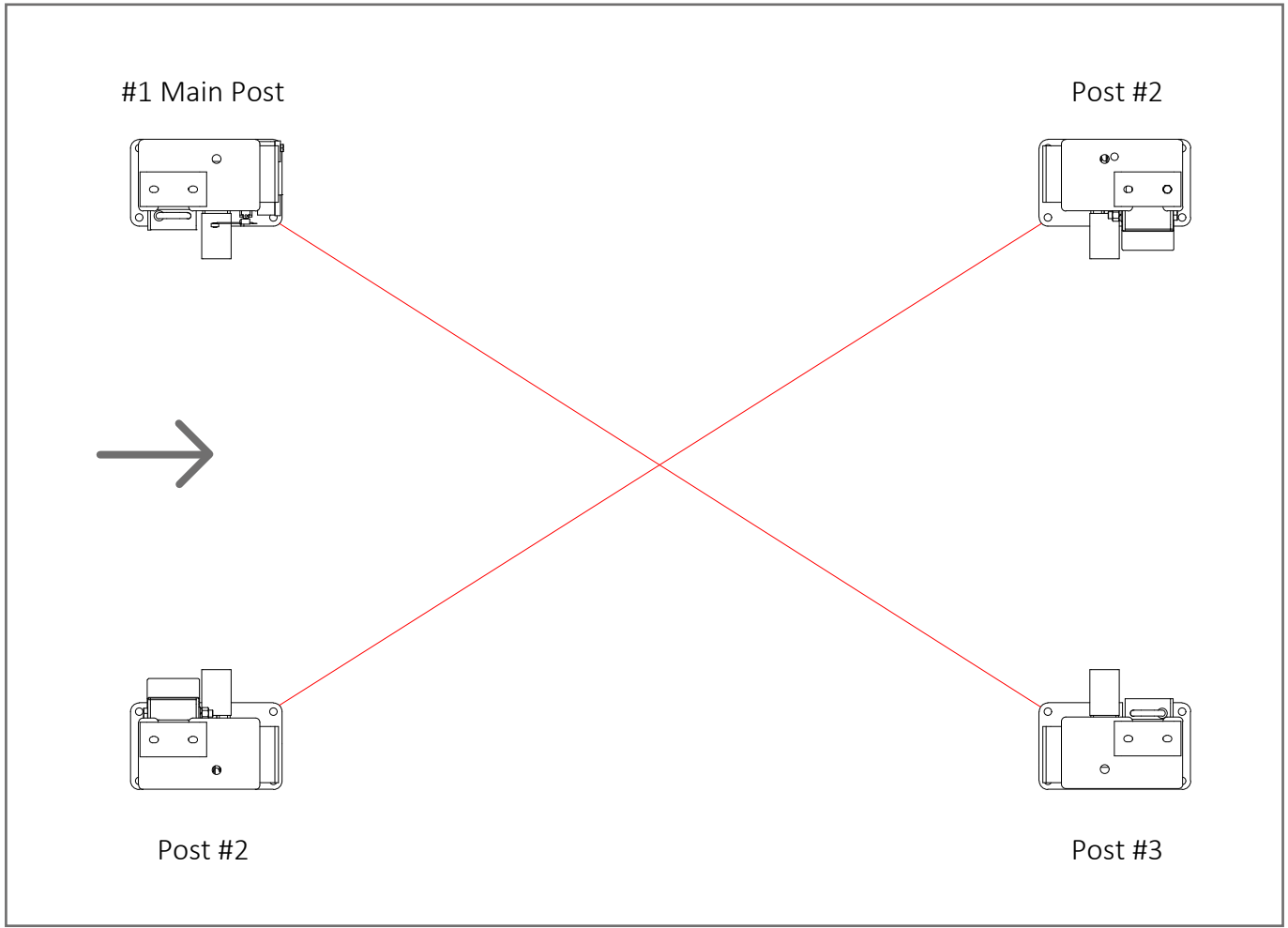

(5) Arrangements of four posts

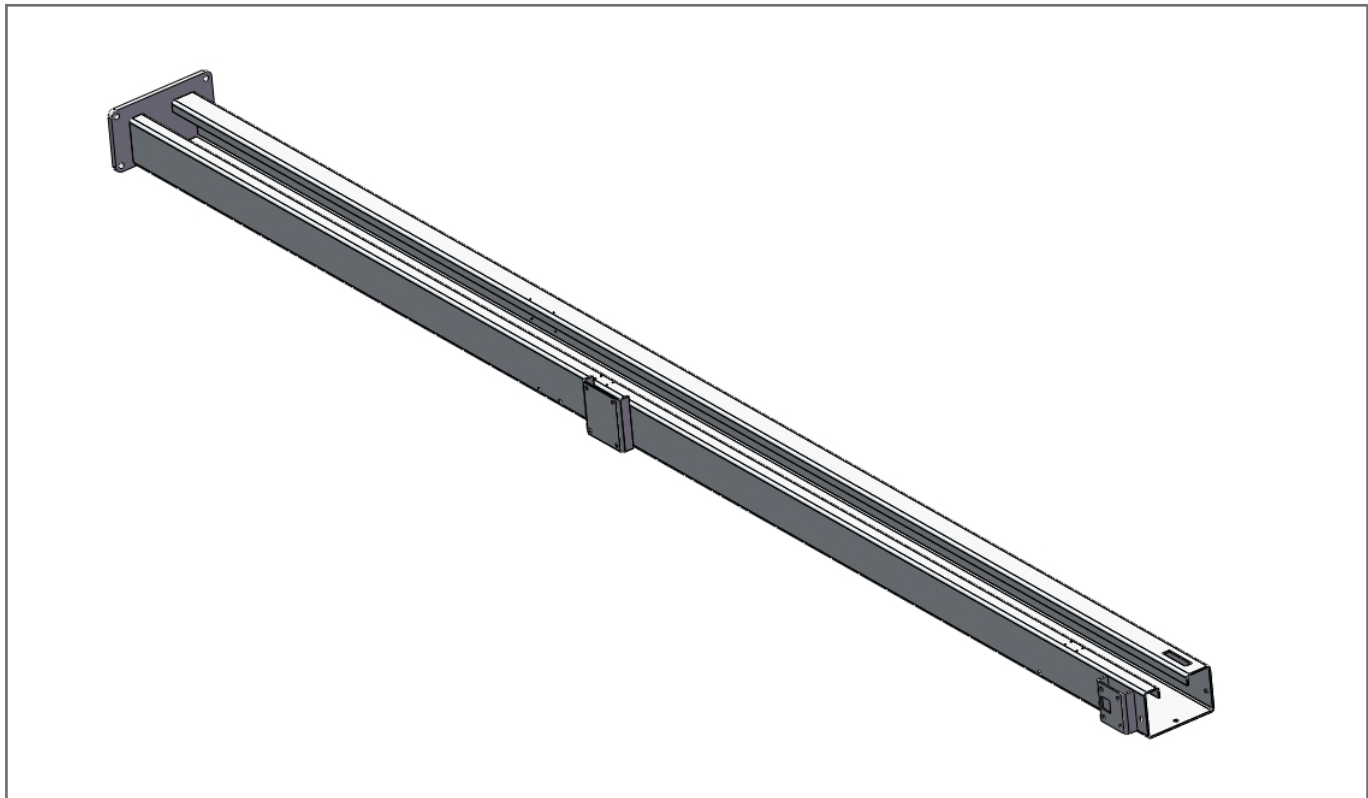

(6) Baseplate for power back in the middle of the Main Post

4.3.2 Cross beams

4.3.2.1 Lay the front posts (#1 & #2) on ground carefully, and connect the cross beams of both upper and lower platforms.

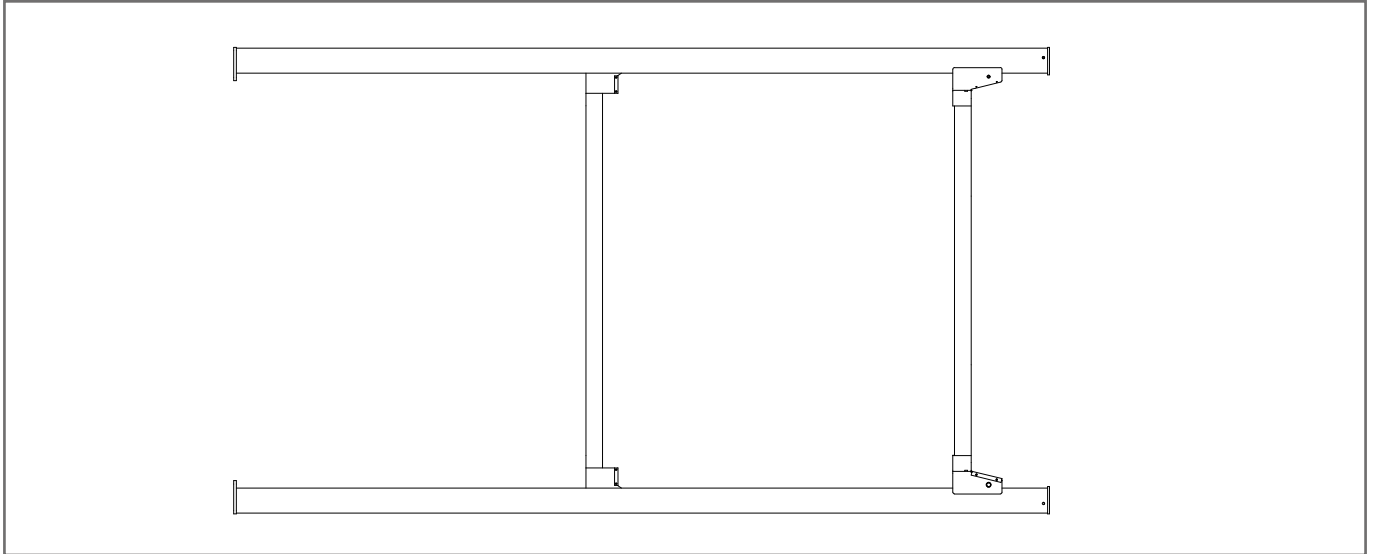

(7) Top view of posts and cross beams on ground

4.3.2.2 Crossbeams of upper platform are at the outer side of post, and crossbeams of lower platform are at inner side.

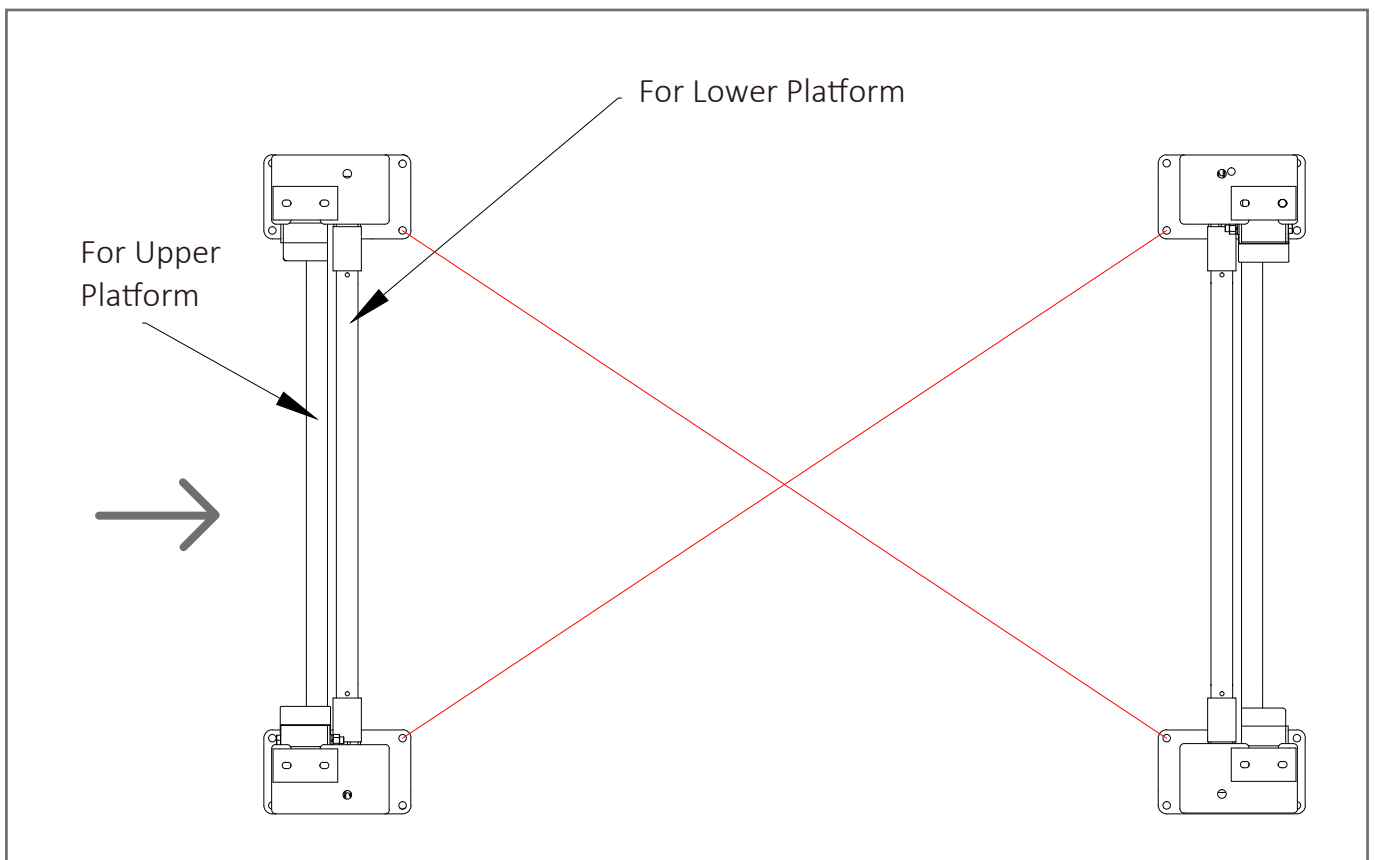

(8) Crossbeam positions of upper & lower platforms.

4.3.2.3 There are full-way anti-falling lock holes on the posts, put the cross beams on lock holes. Crossbeams of the lower platform shall be at least 1m above ground.

4.3.3 Erect the posts

Erect the 4 posts and locate them precisely according to the chalk lines. And insert 2 diagonal anchor bolts for each lift.

! Do NOT tighten at this step.

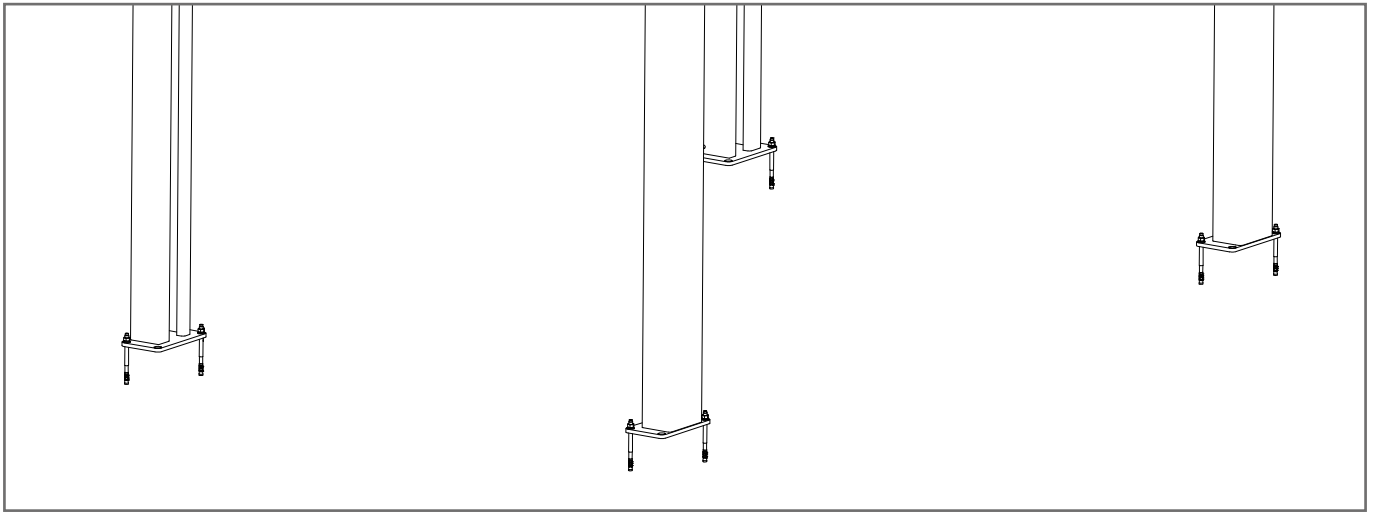

(9) anchor bolts at diagonal

4.3.4 Runways of lower platform

Install the runways of lower platform. The left runway is special and has hydraulic cylinder beneath. The right runway is clean in bottom.

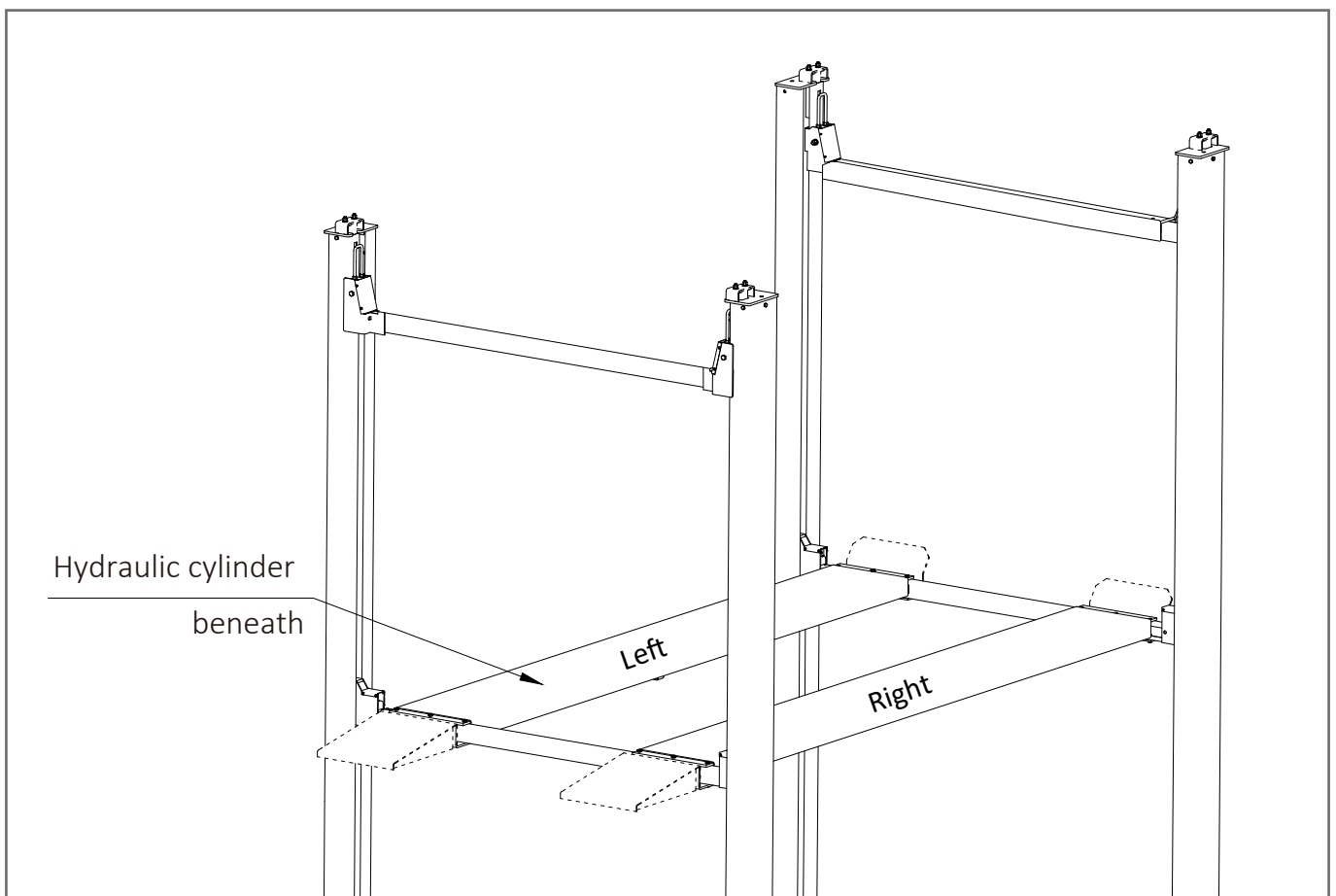

(10) Runways of lower platform

4.3.5 Ramp and wheel stopper of lower platform

Mount the ramps and wheel stoppers for lower platform according to the above figure 4.3.4.

4.3.6 Runways of upper platform

Install the runways of upper platform. Both runways have edge at inner side to hold cover plates.

! A clearance of minimum 50mm **MUST** be kept between upper and lower platforms.

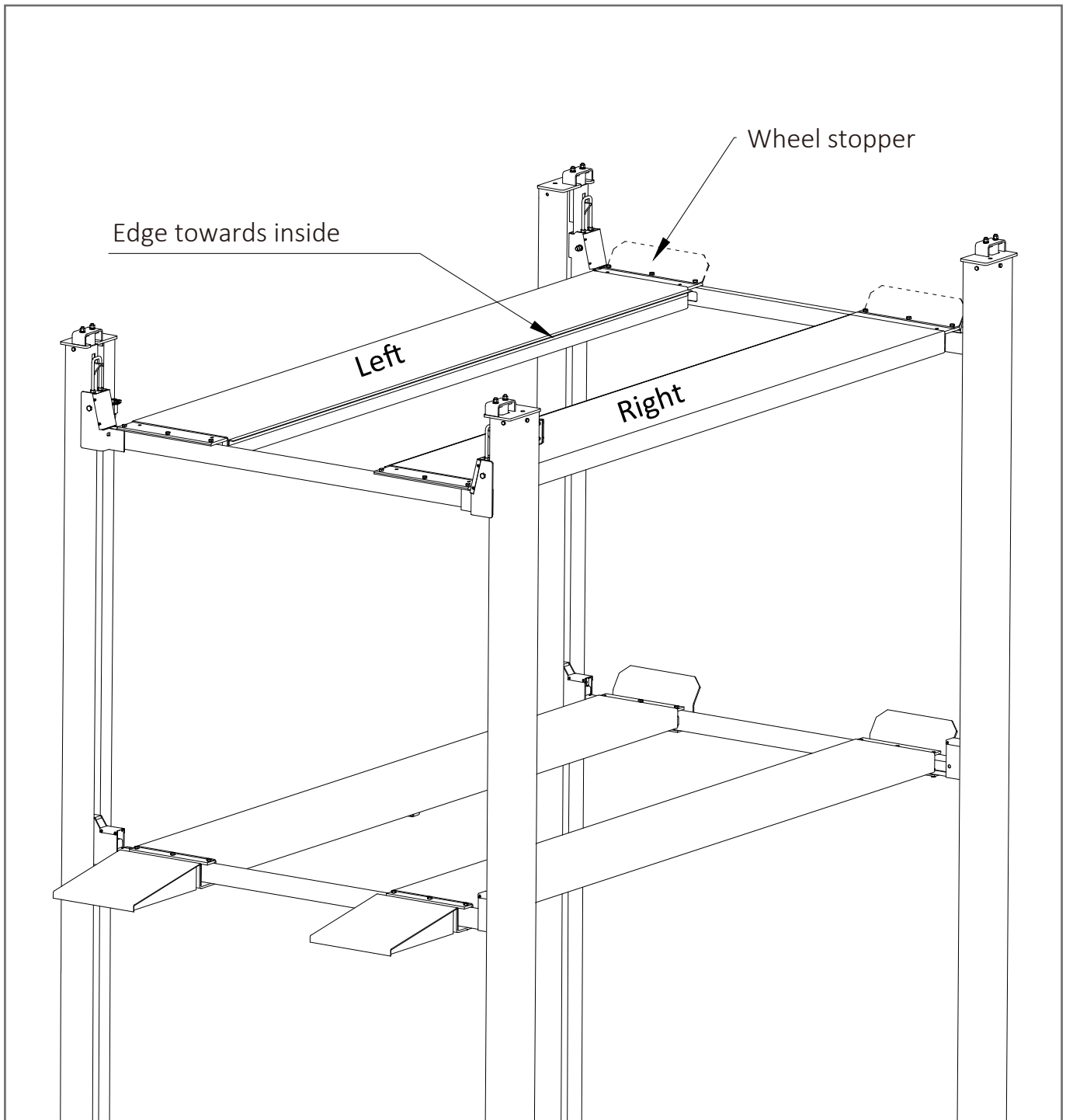

(11) Runways of upper platform

4.3.7 Wheel stopper of upper platform

The way of installation is same as for lower platform.

4.3.8 Side beams

Connect the front & rear posts with side beams. Do NOT fasten for now.

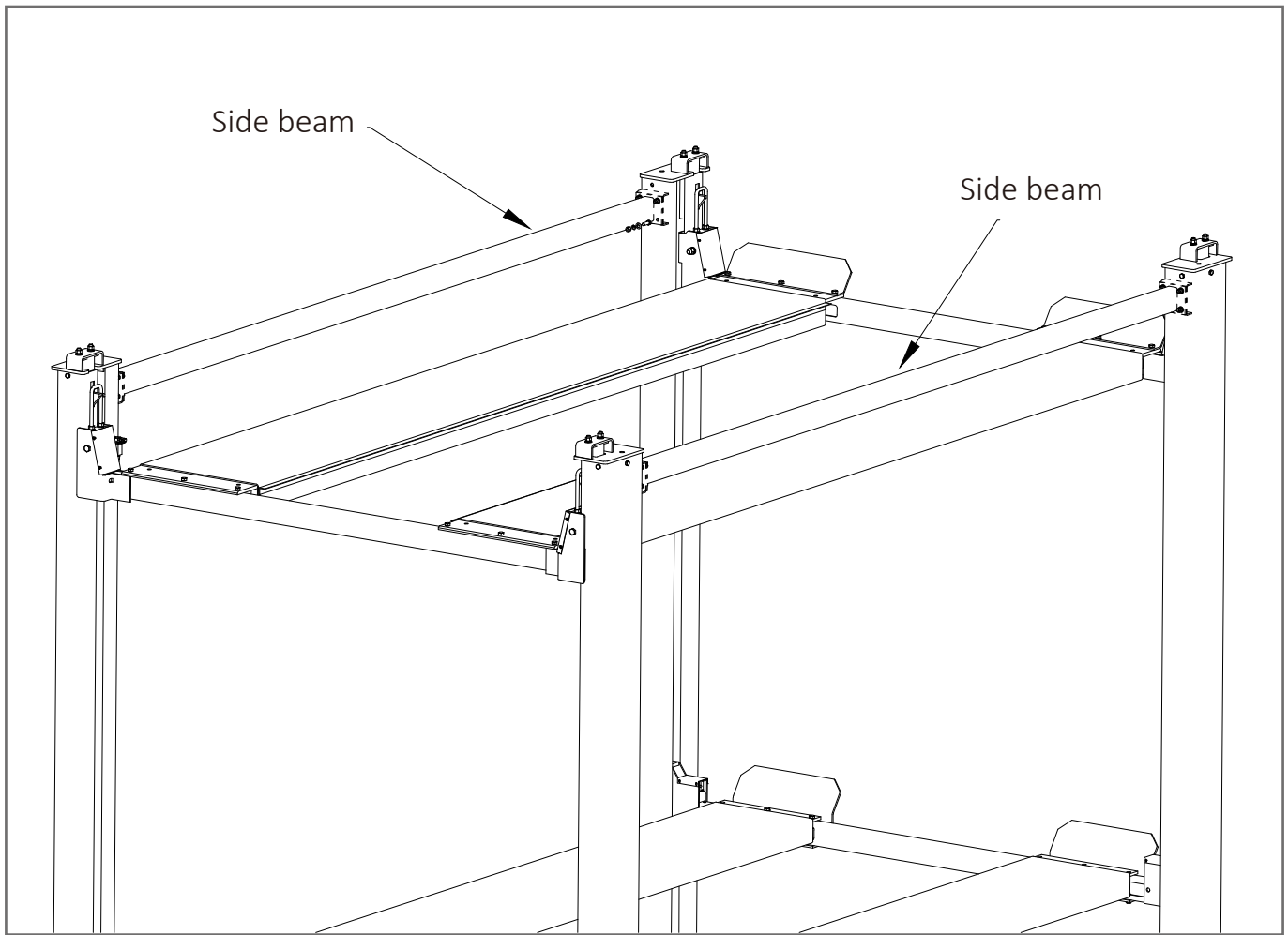

(12) Side beams

4.3.9 Top cover plates

Preassemble the cover plate and anti-falling lock (triangle-shaped) on ground, and then install the cover plates for each post on top, as well as the U-shaped hooks. Fasten by bolts & nuts.

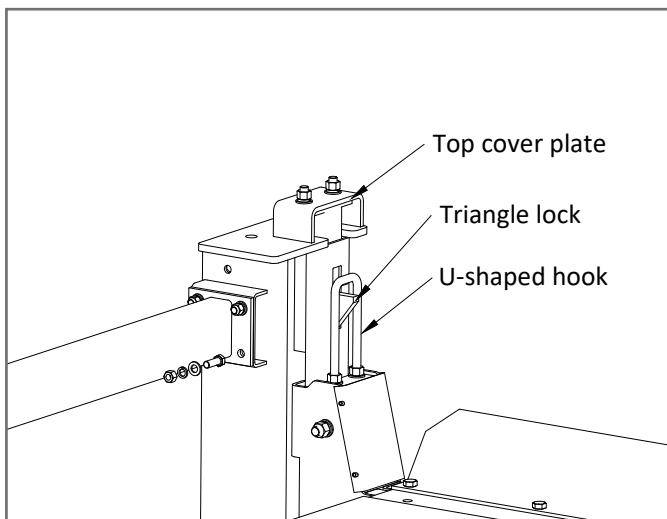

(13) Cover plate & lock on Post #2

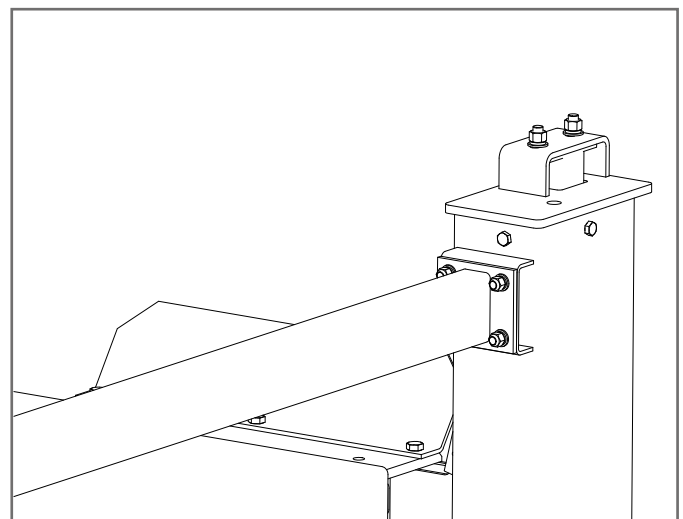

(14) Cover plate for Post #3

4.3.10 Steel rope wiring

Steel ropes are arranged beneath Left Runway, and have been pre-wired together with hydraulic cylinder.

Find the 4 rope heads and direct them to the direction of 4 posts, then pass the ropes into inside of each post through the Bigger Window beneath anti-falling lock holes.

Then the ropes go all the way to the top of each post, and fixed by double nuts and washer.

Fasten or loose the nuts to make sure that the two platforms are leveled.

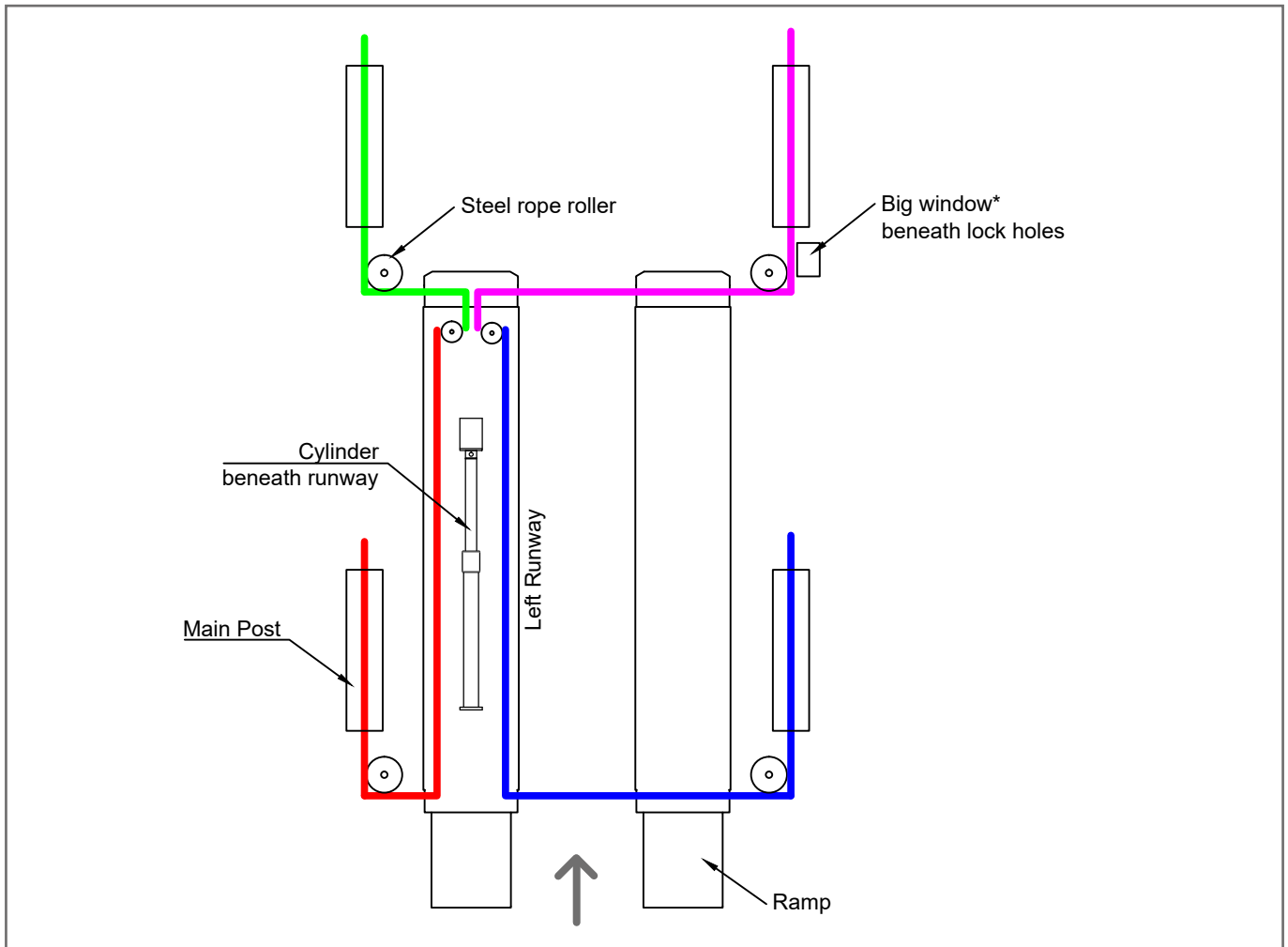

(15) Steel ropes wiring

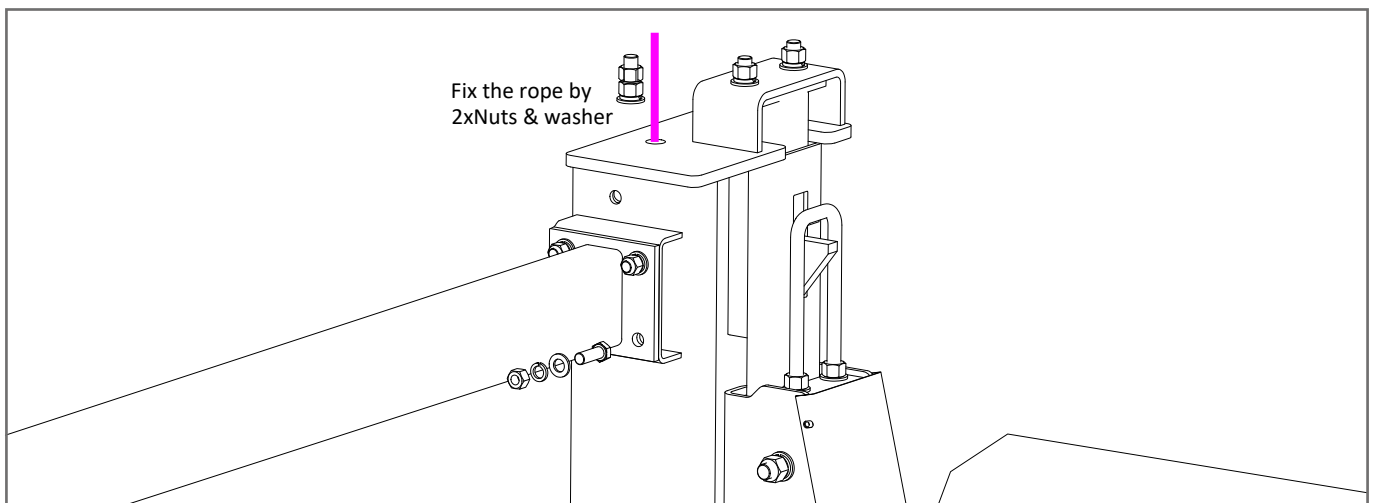

(16) Fasten steel ropes on post top

4.3.11 Inject oil into oil tank

The power pack works with #46 hydraulic oil, anti-wearing type, 12 liters. This oil is suitable for normal temperature; for low temperature areas, #32 hydraulic oil is recommended.

4.3.12 Power pack

Power pack is mounted on the Base Plate of Main Post.

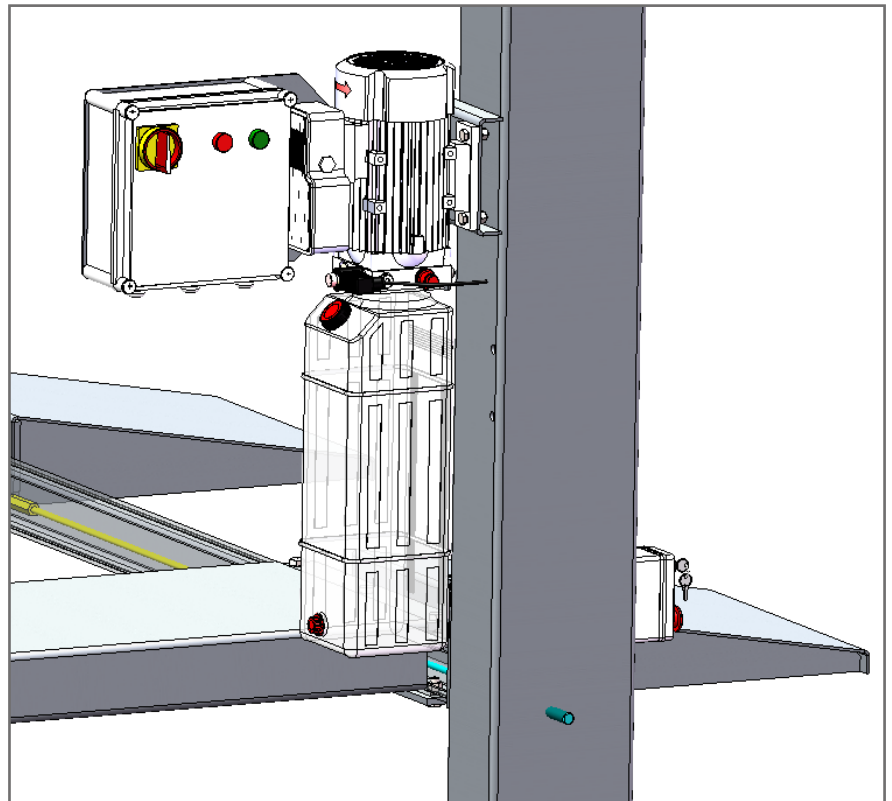

(17) Mount power pack on Main Post

4.3.13 Electric box

Electric box is mounted on the motor of power pack through a backboard.

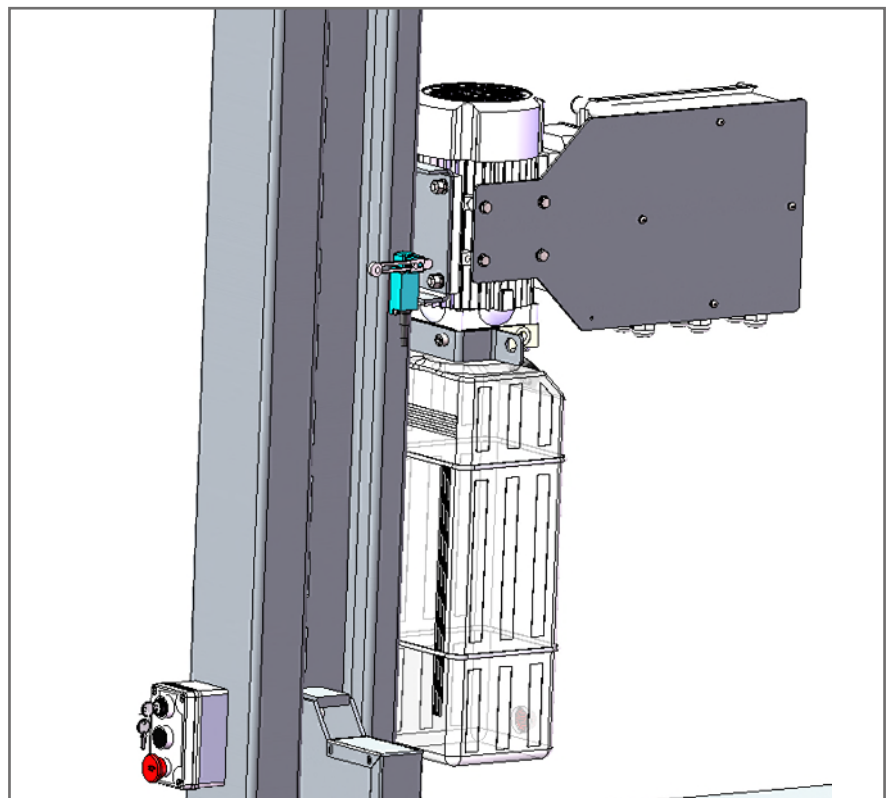

(18) Mount electric box onto Motor

4.3.14 Key switch

Key switch, also known as control panel, is with key and emergency stop button. Mounted on the main post also, front side. Holes have been reserved in factory.

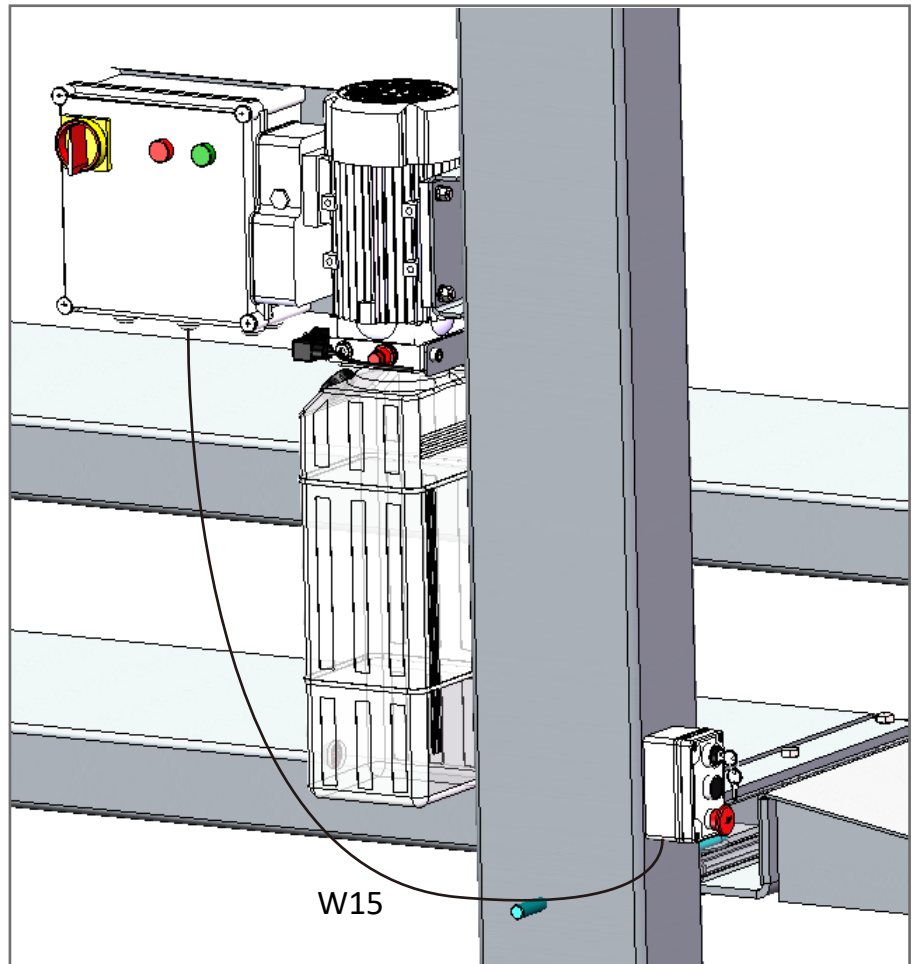

(19) Key switch on front of Main Post

4.3.15 Hydraulic oil lining

One piece of oil hose has been connected with cylinder beneath the left runway in factory. Connect the rubber oil hose between pump and the port on front cross beam of lower platform as showed in below figure.

The cable W5 is for electromagnets of Lower Platform (W6, W7 & W8), details mentioned in 4.3.18. The oil tube & cable W5 shall be wrapped together with spiral cover.

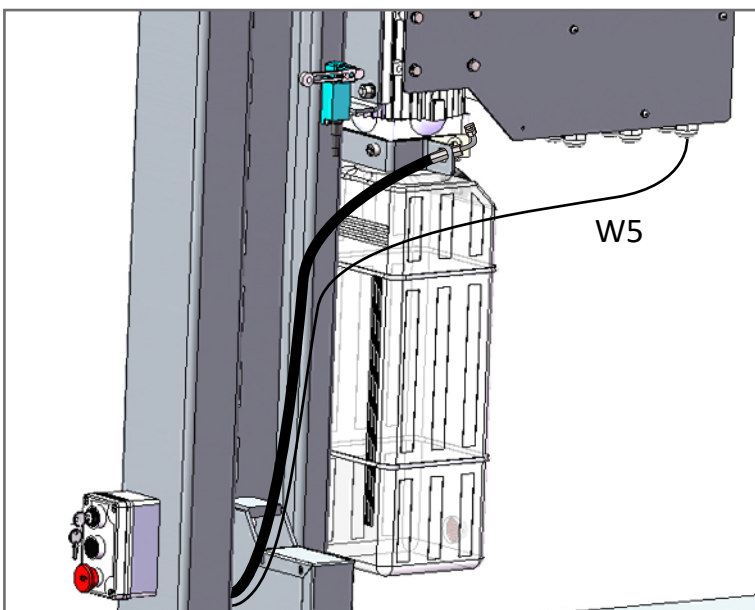

(20) Oil tube lining

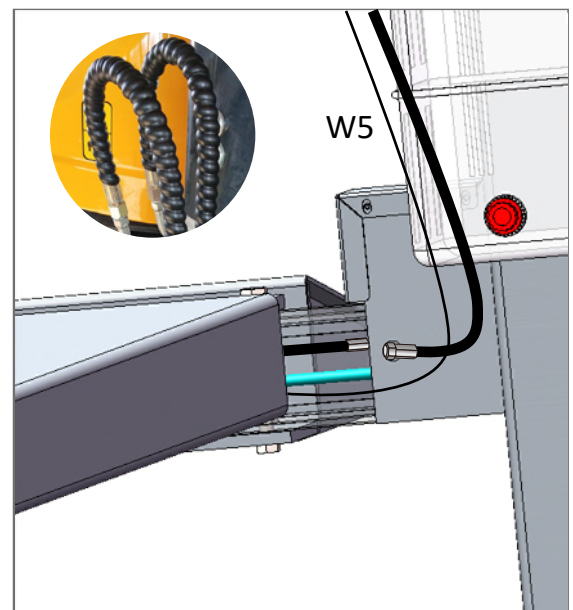

(21) Connecting hole on Cross Beam

4.3.16 Fasten all the bolts on the structure

Fasten all the bolts on the main structure, excluding the anchor bolts.

4.3.17 Limit switch

Limit switches (2pcs) are fixed on the main post, one for lower platform and another for upper platform. Installation holes have been drilled in factory.

The upper limit switch is around 4600mm high, close to the post top.

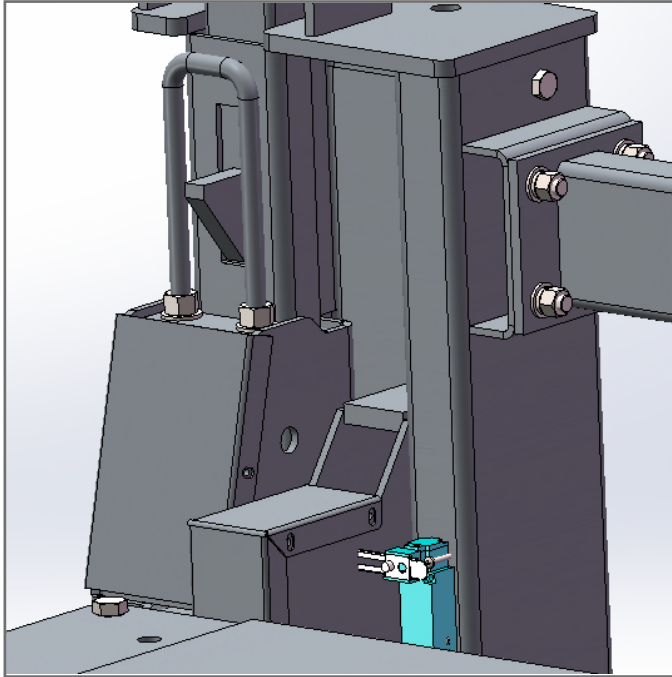

(22a) Upper limit switch, color Blue

The lower limit switch is at the height of approx. 2200mm close to the baseplate for power pack.

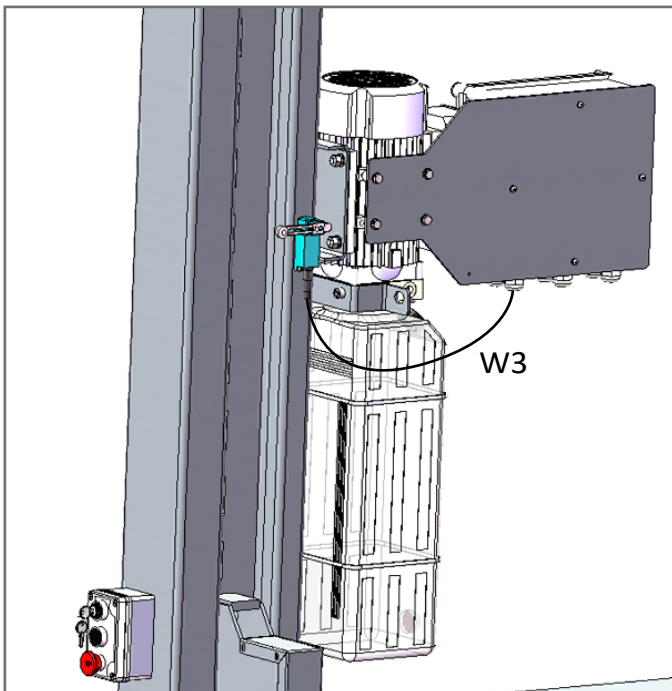

(23) Lower limit switch, color blue

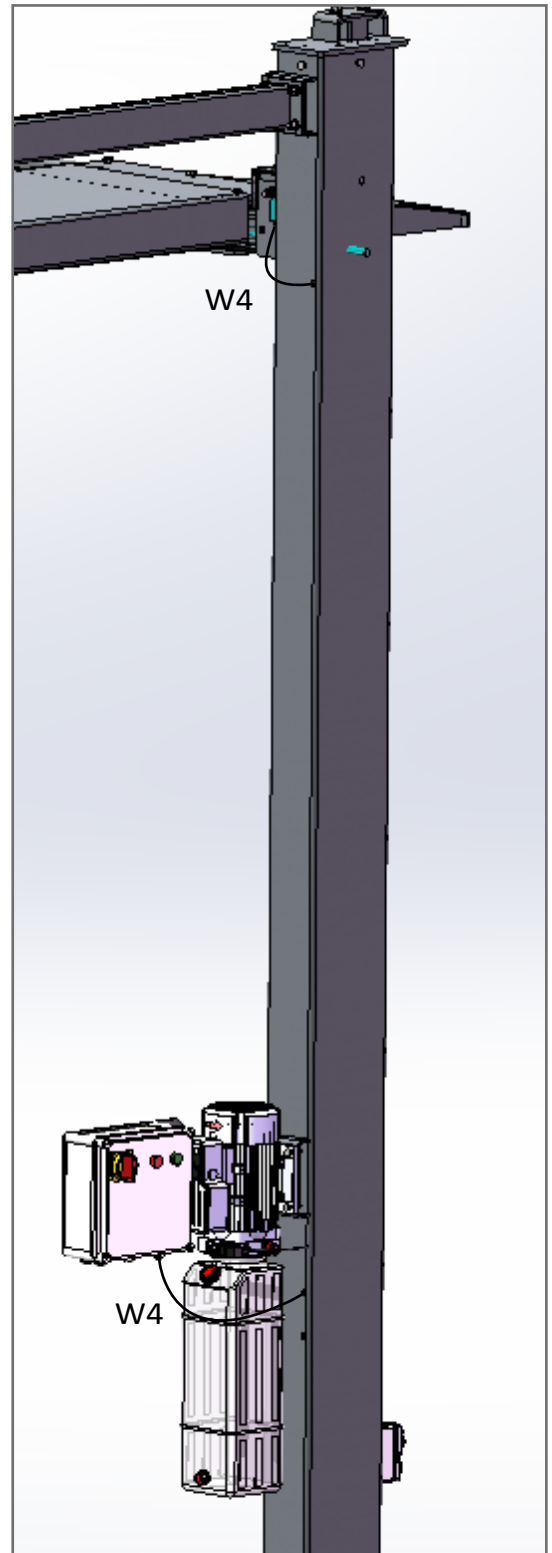

(22b) Upper limit switch, color Blue

4.3.18 Wiring of electromagnets

All the electromagnets for Upper Platform (4pcs) are installed on post top, together with cover plate. Please do the wiring (W11, W12, W13 & W14) according to the below diagram, all of them are started from W10.

Electromagnets for lower platform (4pcs) have been pre-assembled with front & rear crossbeams, do the wiring (W6, W7 & W8) according to below diagram too, which are started from W5.

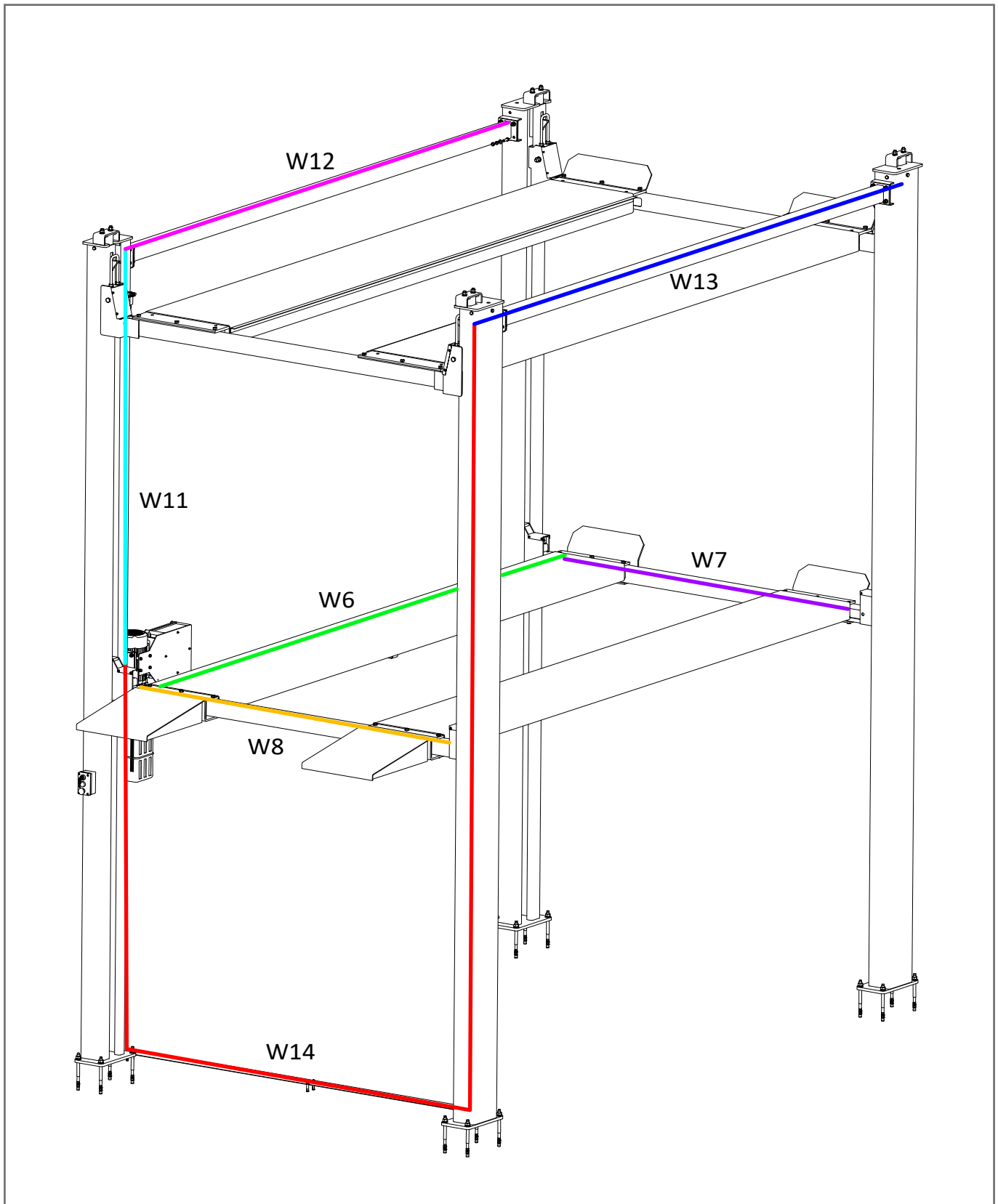

(24a) Wiring diagram of electromagnets for Upper Platform

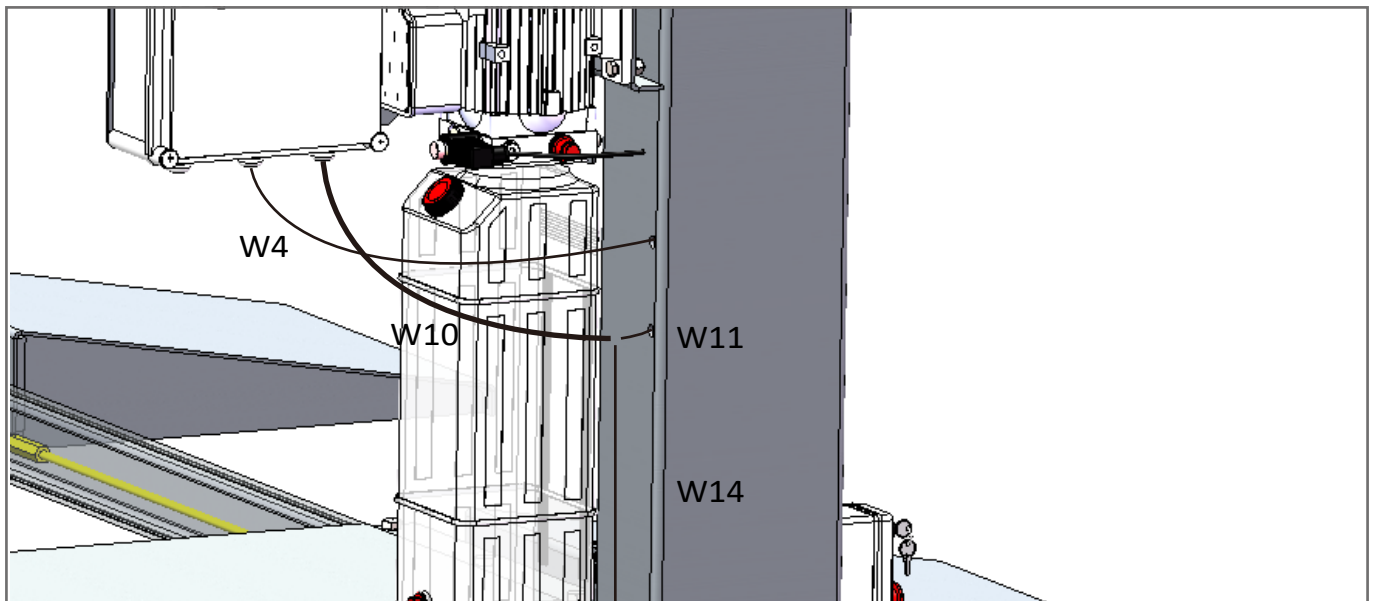

(24b) Wiring details

4.3.19 Main power cable

Feed power to the electric box, which can be bundled together with Cable W14, and are protected by aluminum cover.

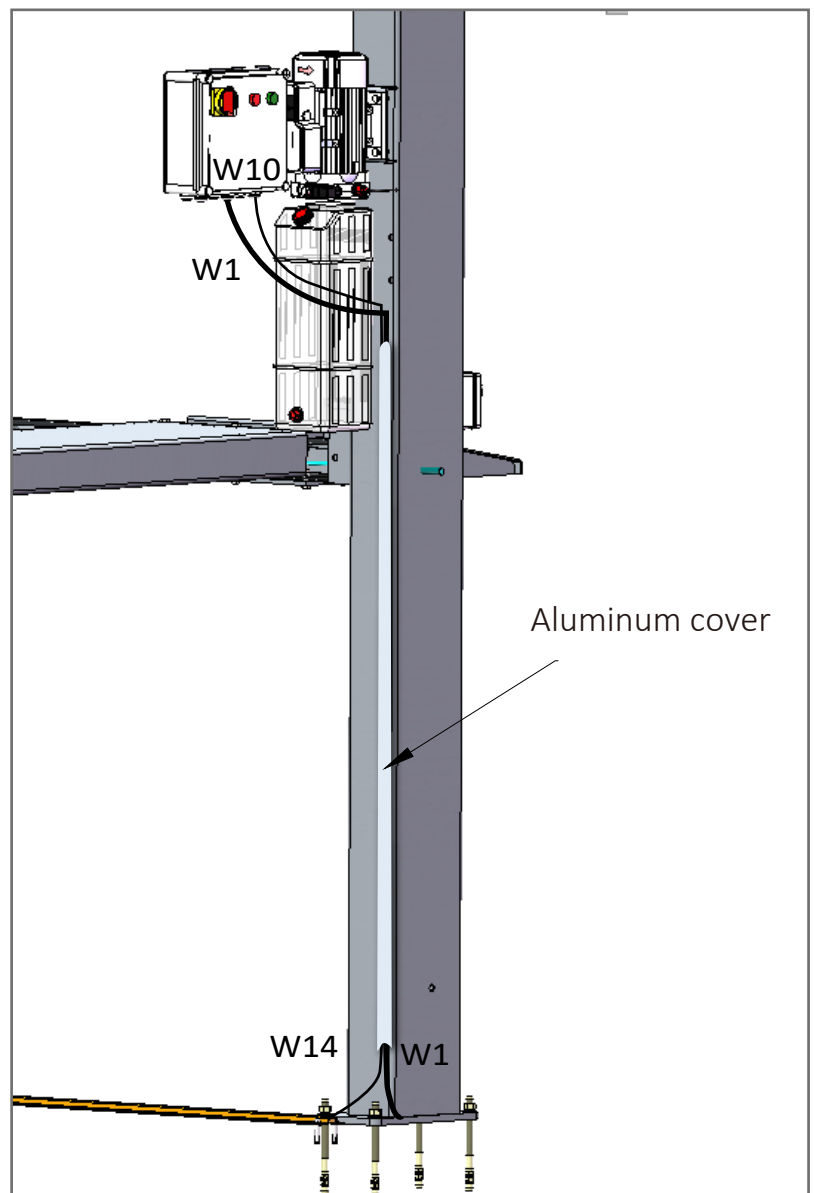

(25) Power cable lining

4.3.20 Test run

Feed power to the parking system according to electrical diagram in chapter 5.4 Electrical Diagram, and test run for couple of times.

Re-adjust the levelness of steel ropes and platforms if necessary.

4.3.21 Fasten the anchor bolts

Once the platforms are leveled, fasten all the anchor bolts.

4.3.22 Cover plates of platforms

There are 5 covers plates for each platform between left and right runways.

For the upper platform, the cover plates can be simply lay into the middle of runways.

For the lower platform, the cover plates shall be screwed together with runways.

! Please note that the screws must NOT cause any damages to sliding blocks beneath Left runway of lower platform, any protruding screw heads facing sliding blocks MUST be cut off.

4.4 Final Checklist

Make sure that all the below items have been satisfied before putting your parking lift into service:

- Review the entire installation steps and make sure that all steps have been executed correctly.
- Make sure the power pack has gotten power from the power source.
- Make sure that enough hydraulic oil has been put into oil tank, with correct oil grade as required.
- Check the hydraulic oi tubings for any leaking points.
- Check the four posts, which shall be properly anchored and leveled.
- Make sure all the steel ropes are routed correctly.
- Make sure all the safety locks and electromagnets are working fine.
- Make sure the emergency stop button is well functioned.
- Make sure you have left this User Manual to the operator or your customer.

4.5 Parts drawings

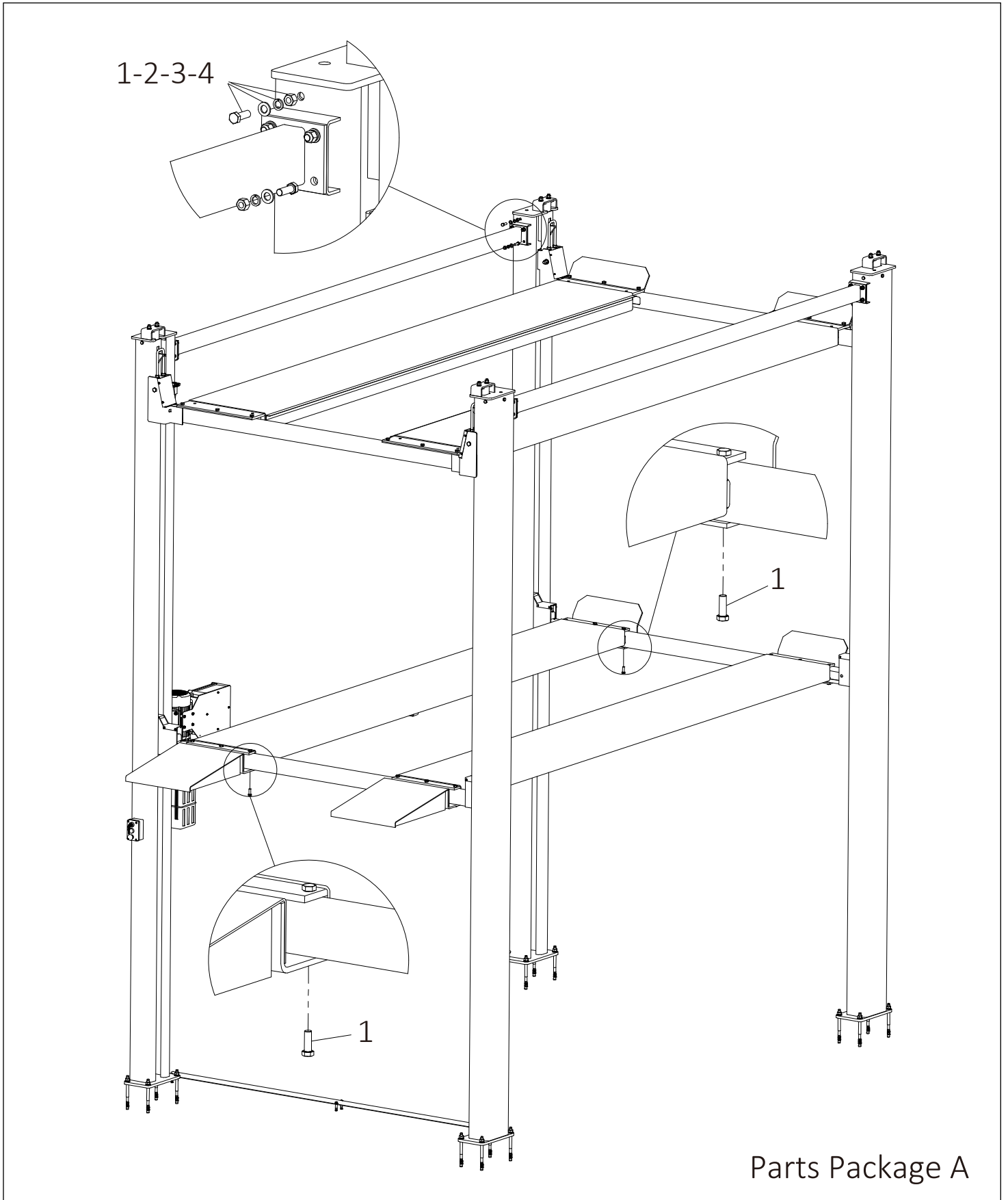

Parts Package A

NO.	Item Name	Spec.	Qty.
1-2-3-4	Hexagon Bolt	M12*35	28
1	Hexagon Bolts	M12*35	12

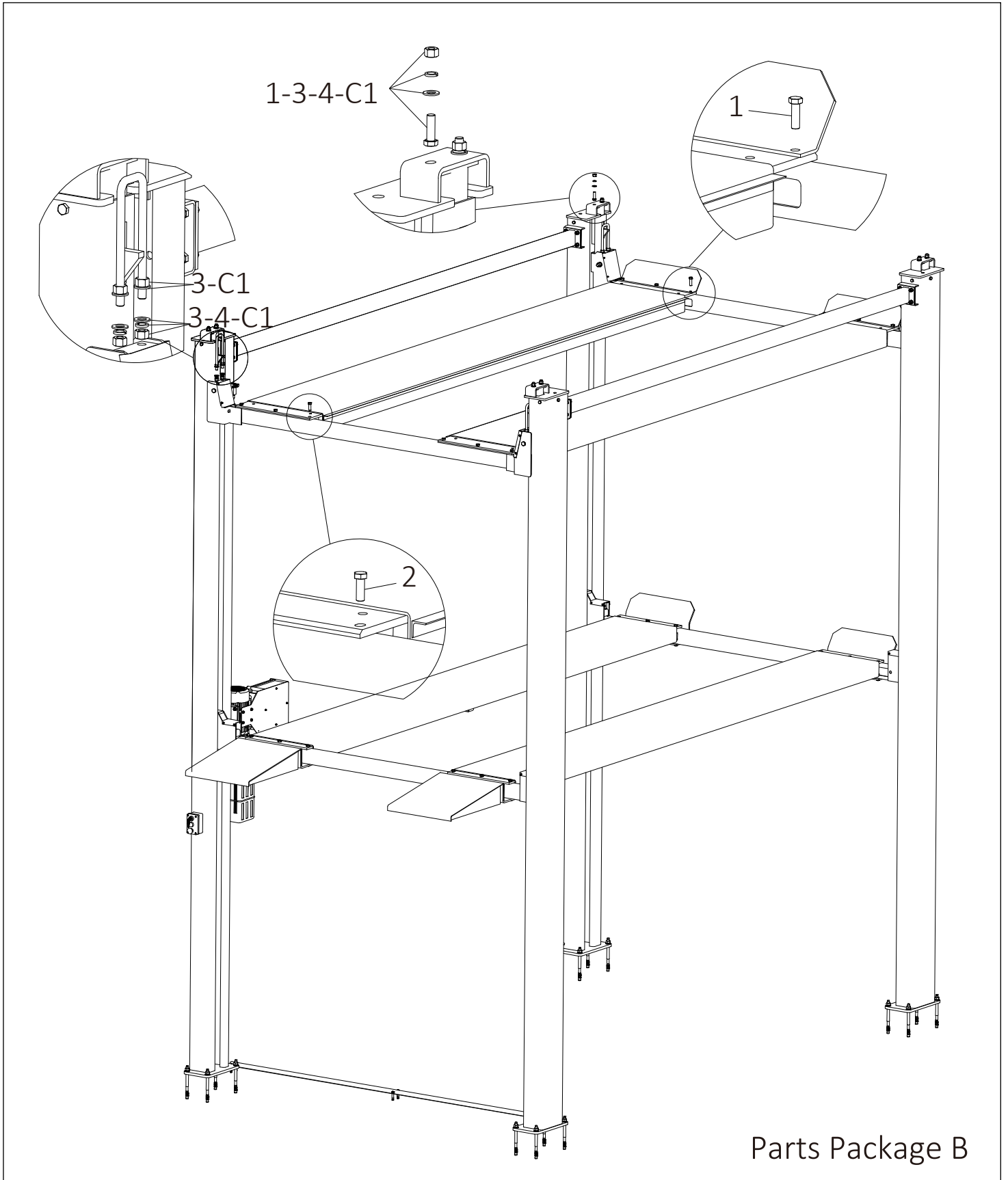

Parts Package B

NO.	Item Name	Spec.	Qty.
1-3-4-C1	Hexagon Bolts	M14*45	8
1	Hexagon Bolts	M14*45	6
2	Hexagon Bolts	M14*40	18
3	Screw Nuts	M14	16
4	Flat Washer	M14	16

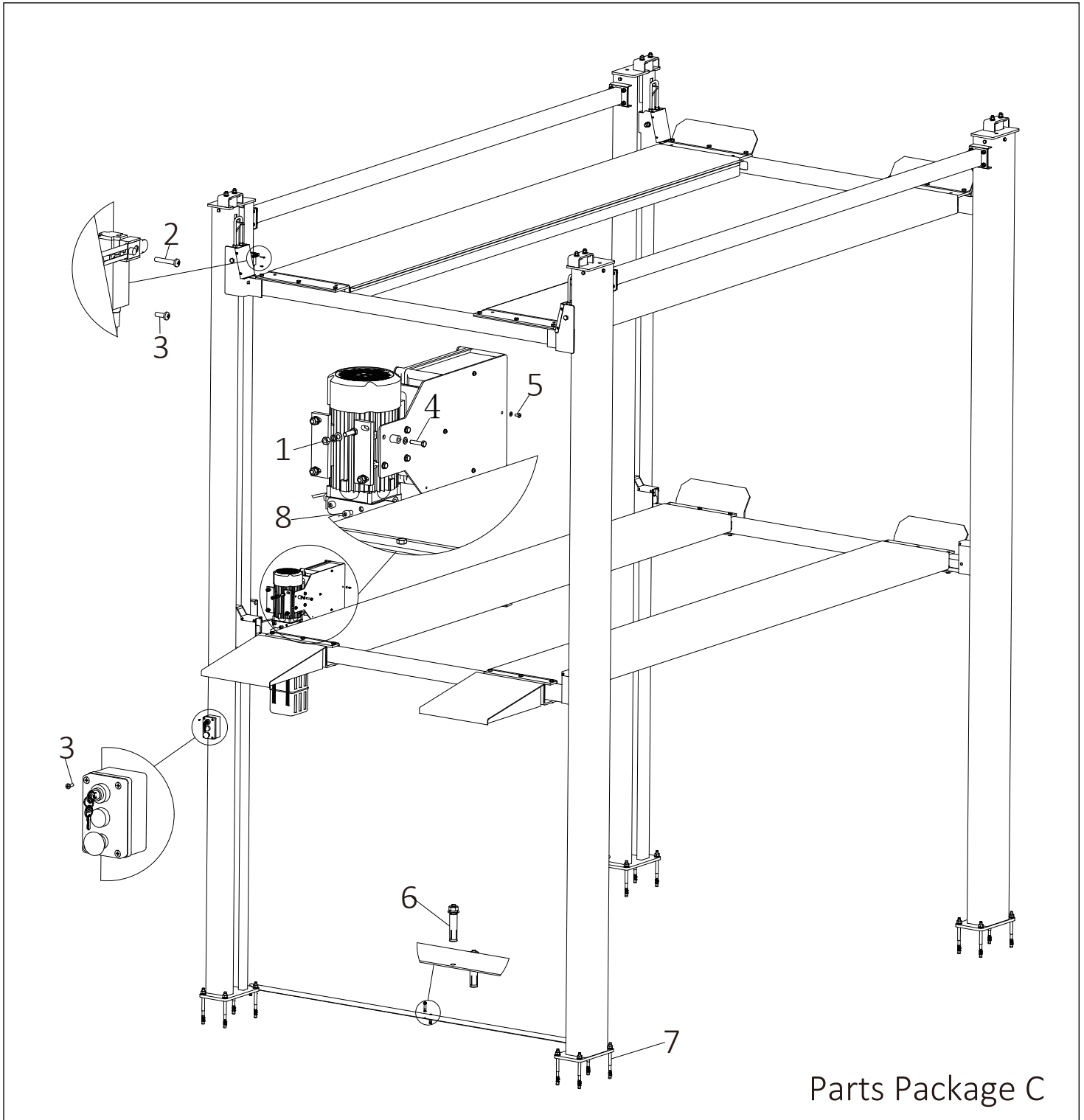

Parts Package C

NO.	Item Name	Spec.	Qty.
1	Hexagon Bolts	M10*35	4
2	Cross Recessed Pan Head Bolts	M4*25	4
3	Cross Recessed Pan Head Bolts	M4*12	8
4	Hexagon Bolt	M8*40	4
	Flat Washer	M8	4
5	Cross Recessed Pan Head Bolts	M5*10	4
	Flat Washer	M5	4
6	Bolted Anchor Bolts	M8*65	6
7	Bolted Anchor Bolts	M16*220	2
8	Hexagon Socket Bolts	M12*15	2

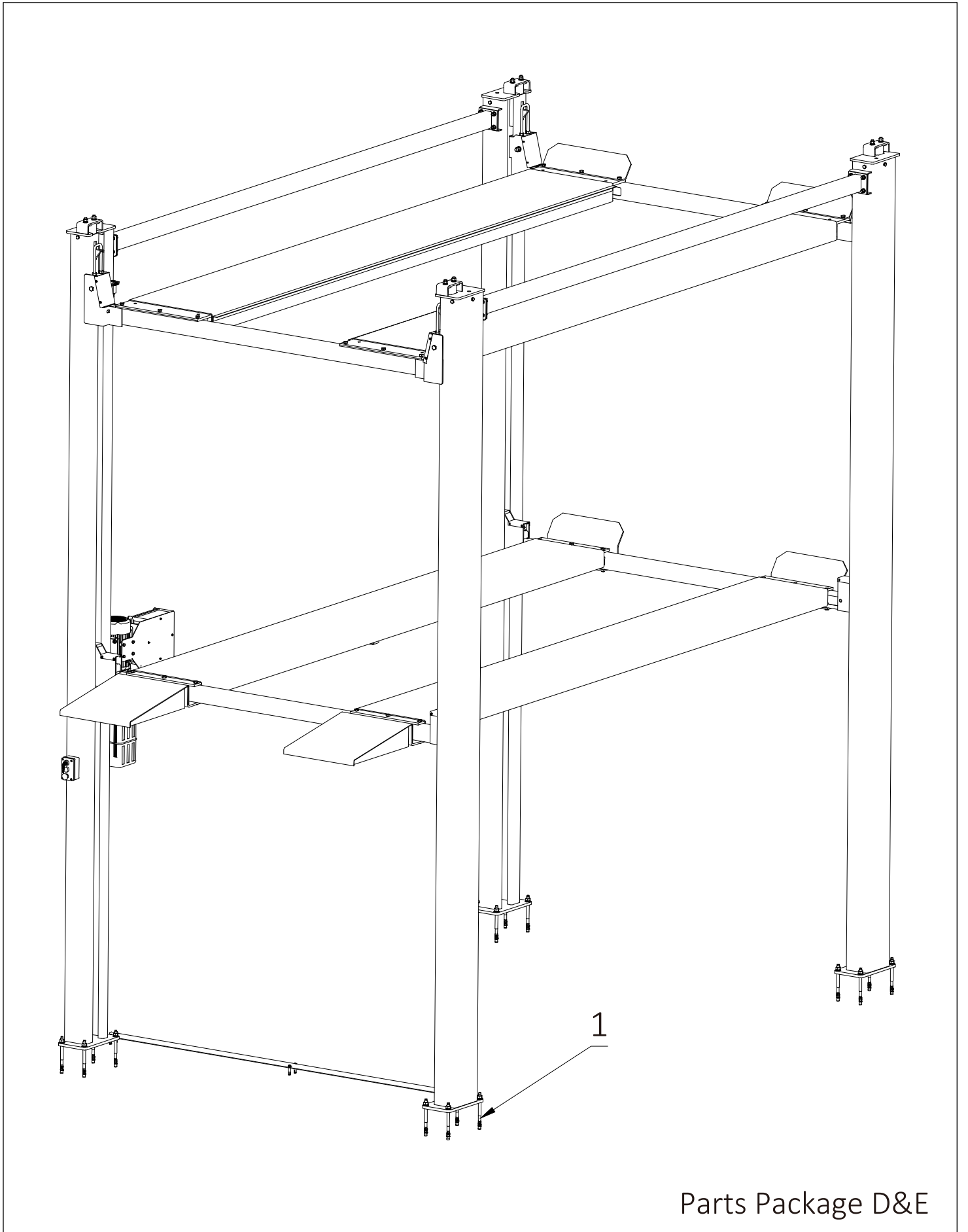

Parts Package D&E

NO.	Item Name	Spec.	Qty.
1	Bolted Anchor Bolts	M16*220	7

5 Hydraulic & Electrical

5.1 Hydraulic diagram

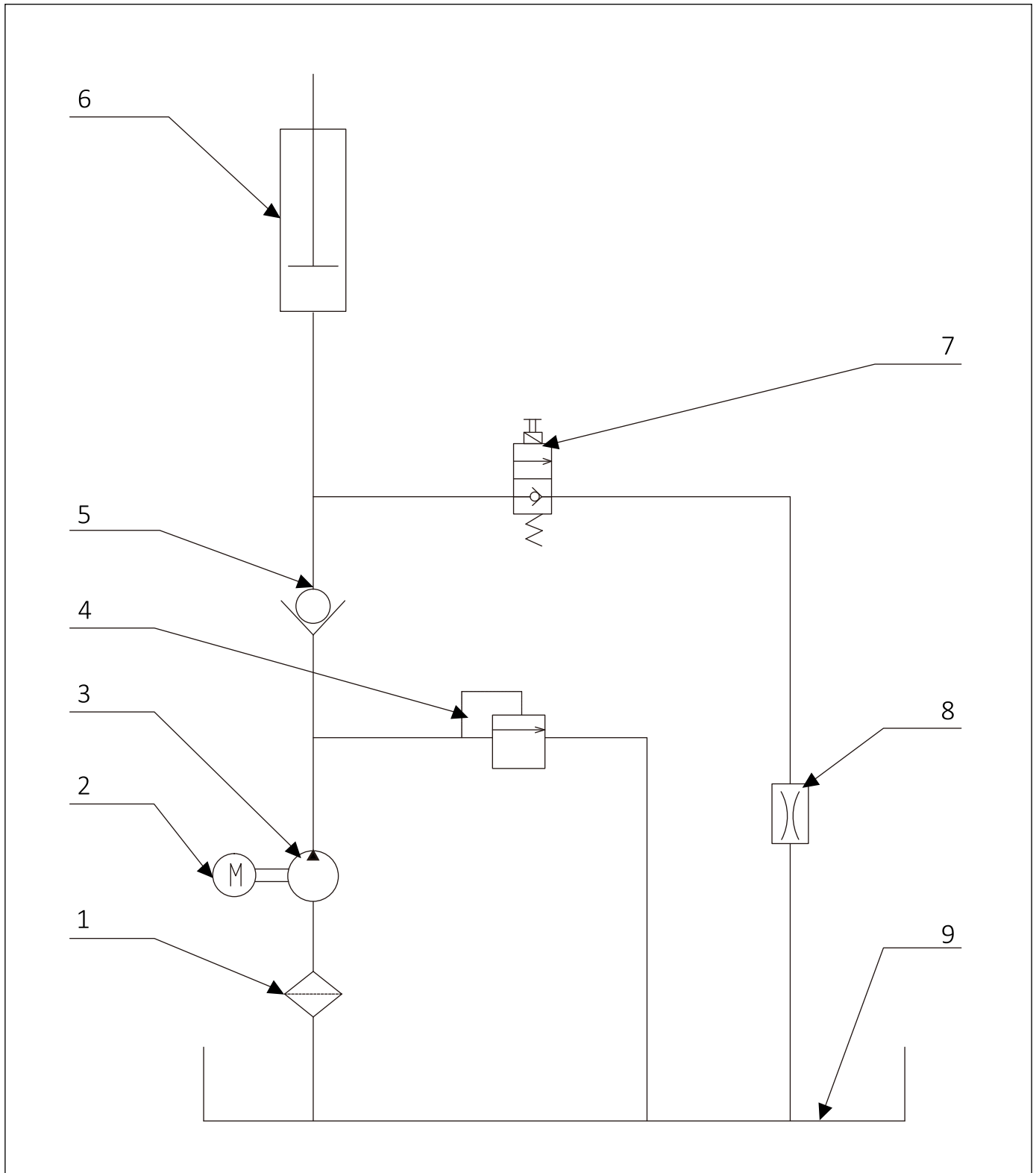

1	Filler	6	Cylinder
2	Moter	7	Solenoid valve
3	Gear pump	8	Throttle valve
4	Relief valve	9	Oil tank
5	One-way valve		

5.2 Hydraulic diagram

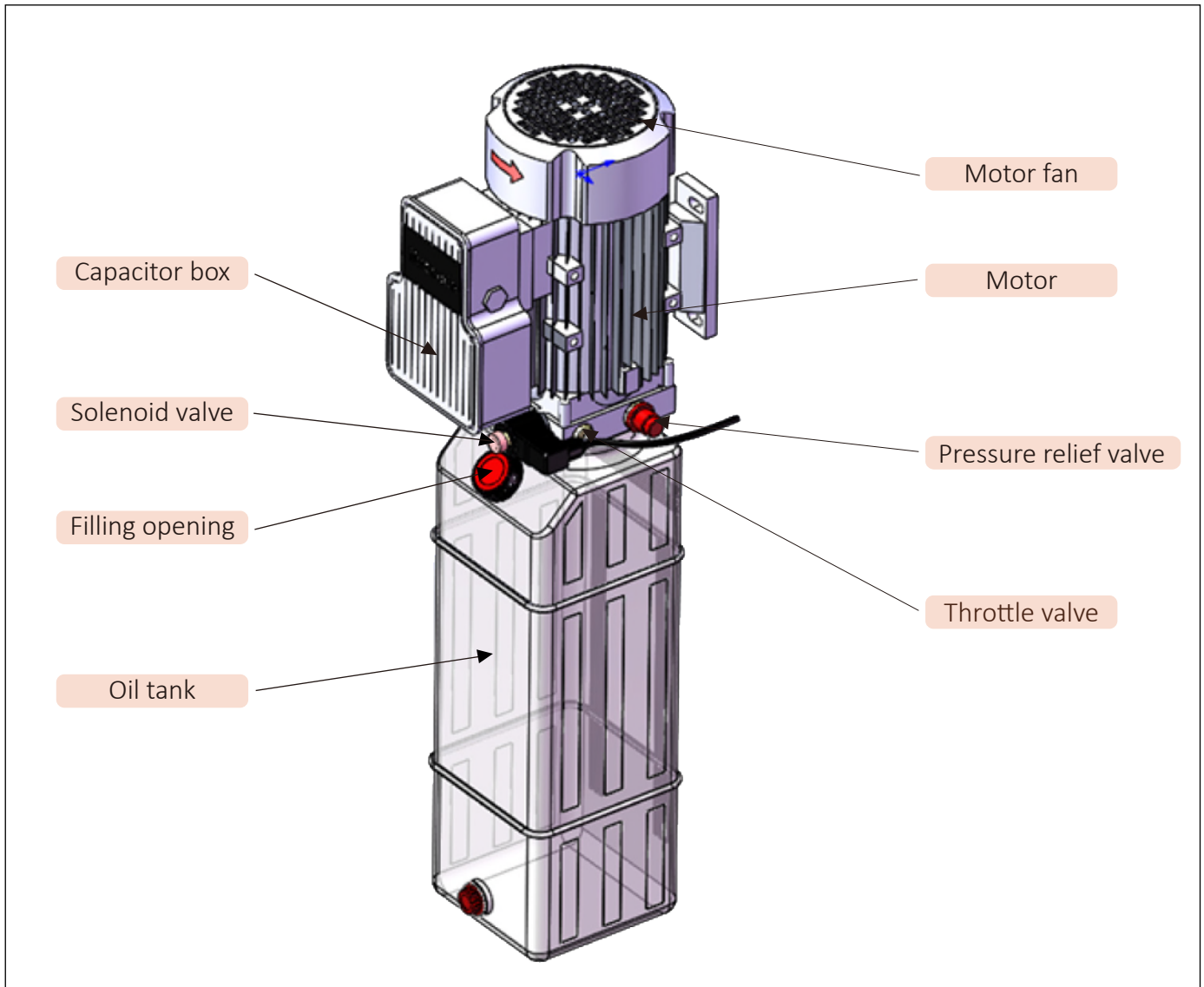

Caution: Serious malfunction even human injury may occur if not properly follow adjustment method requested by manufacturer. Contact Mutrade or local Mutrade partner for permission and technical support before adjustment.

5.2.1 Setting pressure adjustment of pressure relief valve

- 5.2.1.1 Unscrew cap from pressure relief valve, and rotate inner adjusting screw to reset pressure.
- 5.2.1.2 Pressure gauge is essential to set pressure of pressure relief valve.
- 5.2.1.3 Setting pressure will raise approx. 1.2MPa by rotating clockwise adjusting screw with 45 degree, and vice versa. Screw down cap after adjustment finishes.
- 5.2.1.4 Repeat depressurizing and pressurizing to make sure new setting pressure reaches manufacturer's requirement.

5.2.2 Descending speed adjustment

- 5.2.2.1 Unscrew nut on throttle valve.
- 5.2.2.2 15 degree can be rotated each time. Speed of cylinder retracting will be lowered down by rotating clockwise adjusting screw, and vice versa.
- 5.2.2.3 Screw down nut after adjustment finishes.

5.2.3 emergency depressurizing device of solenoid valve

- 5.2.3.1 Screw off cap nut from emergency depressurizing device of solenoid valve.
- 5.2.3.2 Counterclockwise turn the emergency depressurizing screw slowly to make the platform go down.
- 5.2.3.3 Emergency depressurizing screw and cap nut is to be screwed down once platform descends on ground.

5.3 Wiring diagram

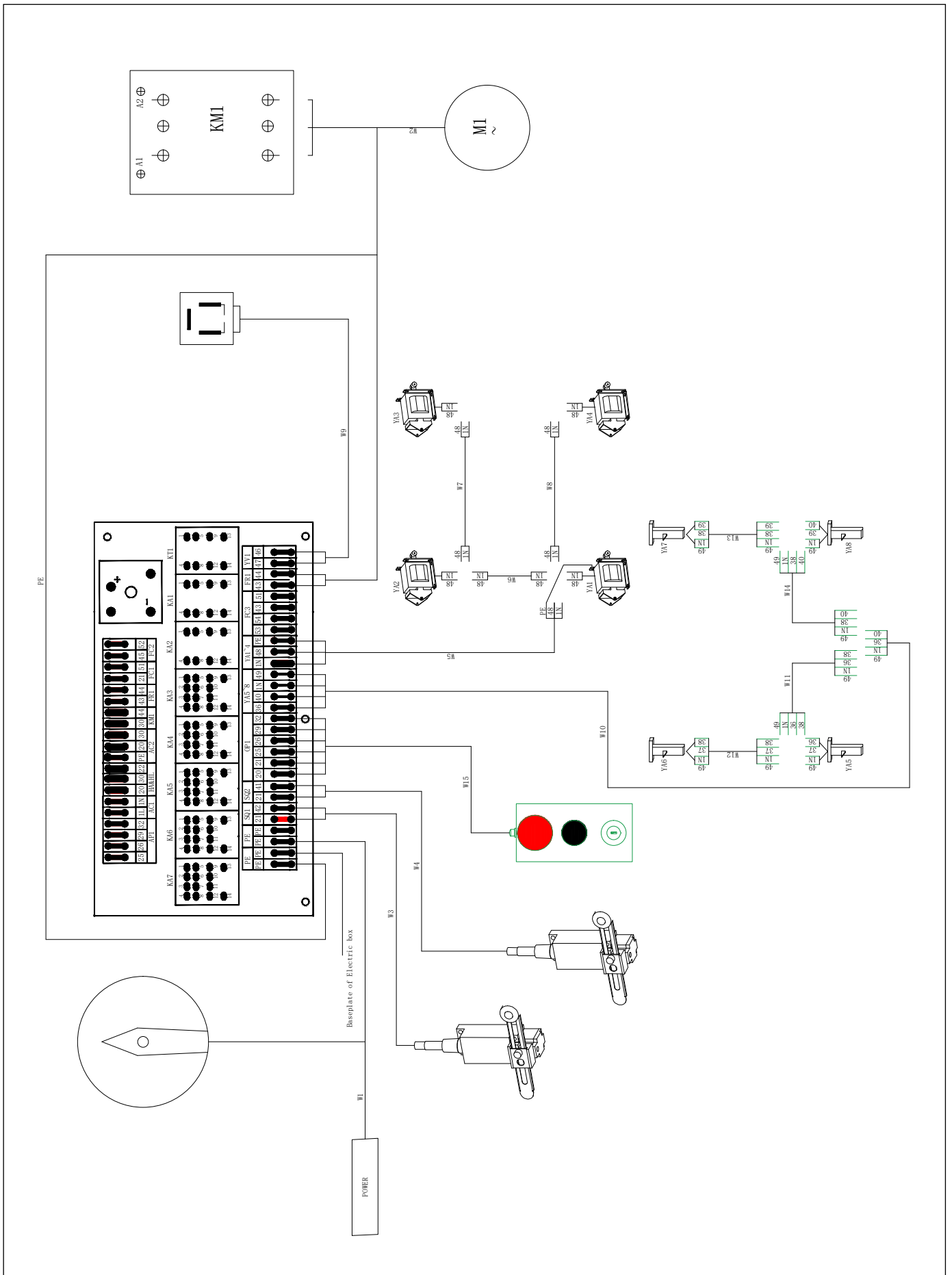

5.4 Electrical diagrams

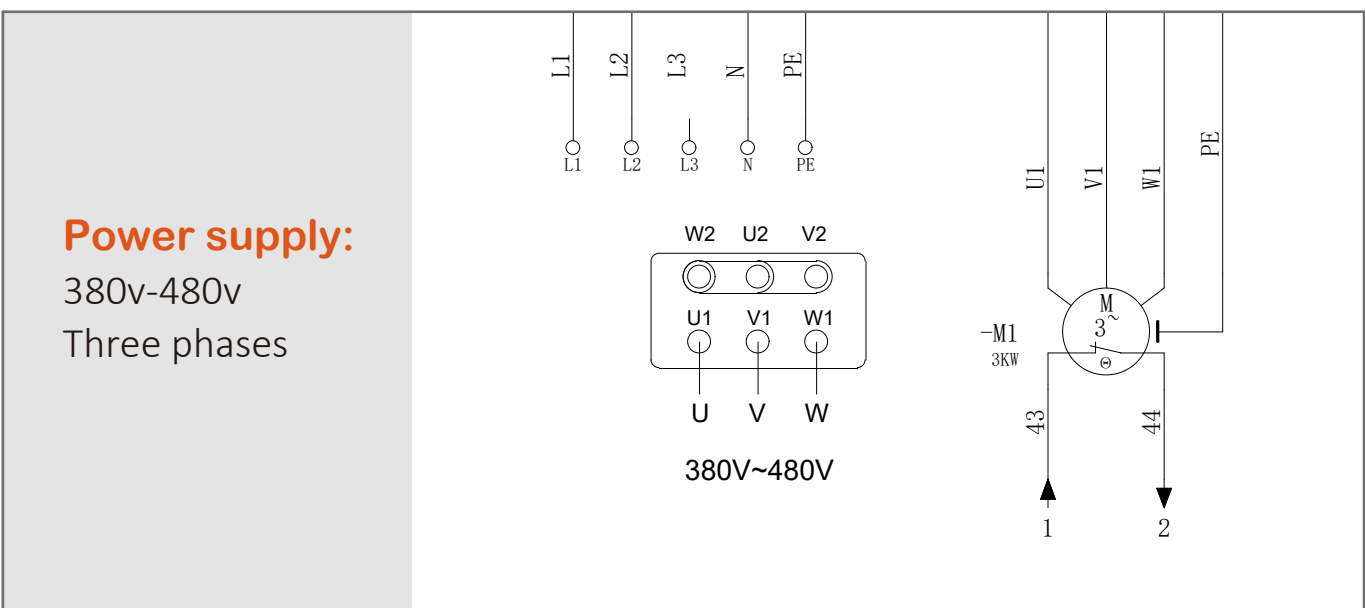
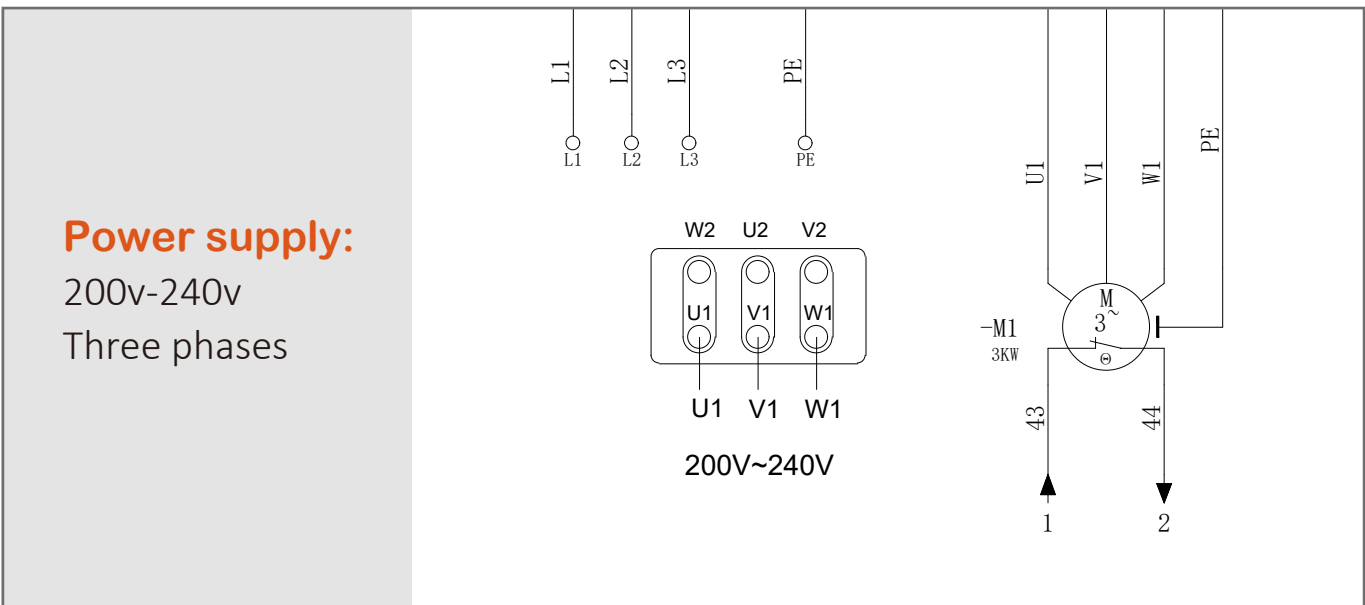
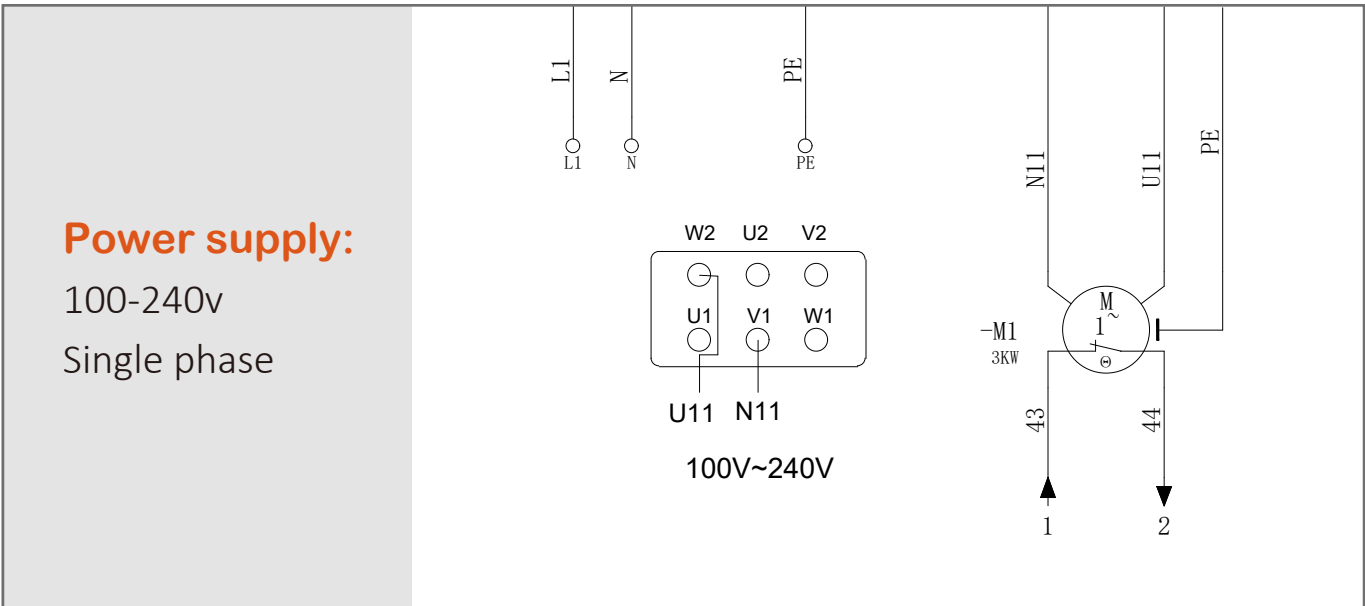

6 Operation

6.1 General notes

- 6.1.1** Only trained persons are allowed to operate the lift
- 6.1.2** Do not operate the lift if the floor is cracked or any components broken.
- 6.1.3** Do not operate if there is any person or obstacles above or under platforms.
- 6.1.4** This equipment is designed for car elevating only, drivers are not allowed to ride the lift or stay in the car.
- 6.1.5** Keep hands and feet away from any moving parts.
- 6.1.6** This parking lift is only designed to lift the entire body of vehicle with maximum weight not more than the rated capacity.

6.2 Parking

- 6.2.1** Drive car onto the center of platforms, avoiding any collision with posts or any other lift structures.
- 6.2.2** Pull the brake on after vehicle parked on the targeted position to avoid any accidental movement during lifting up or lowering down.
- 6.2.3** Over loading is prohibited at any circumstances.
- 6.2.4** Open the car door carefully to avoid any collision.
- 6.2.5** Make sure the car sizes and weight are in allowance range.

6.3 Operation

- 6.3.1** Before first operation, firstly turn on main switch, secondly turn on the power switch on switching cabinet, and thirdly make sure the emergency stop button is open.
- 6.3.2** The power indicator light is off until both main switch and power switch on switching cabinet is turned on.
- 6.3.3** Turn the key by anticlockwise to make the platform go up, and turn the key by clockwise to make the platform down.
- 6.3.4** Pay all your attention on the movement of platform during system working.
- 6.3.5** Release your finger from the Key or push Emergency Stop button immediately to stop lift working in case of any abnormalities.
- 6.3.6** Once the problem related to 6.3.5 solved completely, insert the key for emergency stop button and turn to reset.
- 6.3.7** The buzzer should keep making sounds when platforms move up or down.
- 6.3.8** If not to be used anymore, turn off the power supply, empty the oil tank and dispose the fluid properly according to local regulations.

7 **Surface Cleaning & Protection**

7.1 **Surface cleaning**

7.1.1 Basic cleaning of the platform

A regular cleaning of the platform upper side helps to preserve the system and is absolutely essential.

- The platforms driven over by cars are swept clean by using a broom or vacuum cleaner.

Recommended frequency: Monthly

7.1.2 Cleaning in winter

As the winter months cause more heavy wear due to snow, ice, road salt, chippings etc. when the platform surfaces are driven over, the following measures are to be observed:

- In winter any regular condensation is to be removed in particular below the platforms.
Recommended frequency: Weekly
- Snow, ice, road salt and dirt deposits are to be removed from the platforms.
Recommended frequency: Weekly
- Carry out thorough cleaning of the entire platforms with broom, vacuum or water jet (pressure up to 5 bar).
Recommended frequency: Quarterly

7.1.3 Basic wet cleaning of the ground

- Remove snow, rain, surface water etc. on the ground by cleaning devices e.g., vacuum.

Recommended frequency: Quarterly

7.1.4 Disposal

■ Please follow the codes and regulations of local authorities, such as municipal authorities, environmental protection office or trade supervisory council.

Recommended frequency: As required

7.2 **Surface maintenance**

The parts have undergone different corrosion protection measures, depending on their atmospheric or mechanical loading as well as the individual requirements called for by the client. For an effective long-term protection, the following cares are to be performed:

7.2.1 Screws, nuts, washers

When performing basic cleaning of the units, check all screws, nuts and washers for correct fit. In the event of rust, brush with a brass brush applying light pressure and clean and spray protective wax after cleaning.

7.2.2 Powder coated surfaces

Damage due to mechanical or other effects are to be treated as soon as once detected in order to prevent impairments or infiltration of the powder coating. Care or improvement measures are to be carried out as follows: light rubbing with emery cloth, grain 120 or brass brush (do not use a wire brush!) followed by cleaning and degreasing with brake cleaner. Apply the touch-up paint to the damaged points with a brush, such as, for example Touch-up paint RAL 7016 anthracite grey, air-dried.

7.2.3 Moving parts

Grease the moving parts which might be damaged by dust or damp.

8 Maintenance

8.1 General maintenance

Make sure the power is off and no accidental movement before any maintenance work.

If the equipment will be not in service for a long time, the main power supply should be turned off to avoid any accident and to save energy. It's to be lubricated and inspected if there is any damage and rust corrosion before operation again. And check whether the equipment is in good condition by no-load running.

8.1.1 Daily:

- keep the parking lift clean from any dirt and fluids.
- Visual inspect all moving parts for excessive wear or damages. Replace if necessary.
- Make sure all safety devices (emergency stop button, limit switches, electromagnets, anti-falling locks) are in good operating condition

8.1.2 Monthly

- Check the labels and warning signs on the lift, replace if necessary.
- Grease all moving parts
- Check hydraulic oil level. Refill if low.
- Lubricate the steel ropes.
- Check the steel rope connections for proper fixing and torque
- Check all anchor bolts to make sure they are properly torqued.

8.1.3 Half year

The valve element in solenoid valve and filter in power pack shall be cleaned every half year.

Change all the hydraulic oil three months after first operation; and change oil every 24 months after first changing, or when fluids become dirty.

8.1.4 Every two years

- Change all the hydraulic oil three months after first operation; and change oil every 24 months after first changing, or when fluids become dirty.
- The seals in hydraulic cylinder should be replaced every two years.

Note: the lifetime of hydraulic system may be affected by environment, human factor or lifetime of hydraulic components. Proper and regular maintenance could lower down probability of malfunction.

8.2 Maintenance and servicing of power pack

8.2.1 Inspection of power pack

- 8.2.1.1 Regular inspection
 - ◇ 8.2.1.1.1 Operate the parking lift for a circle to make sure it can be normally pressurized and depressurized.
 - ◇ 8.2.1.1.2 Any abnormal noise during operation should be checked.
 - ◇ 8.2.1.1.3 Working temperature of motor should be checked regularly (shall be from -10°C to +60°C).
 - ◇ 8.2.1.1.4 Check leakages at every oil hose connections. Fasten or replace the fittings if necessary.
- 8.2.1.2 Monthly inspection
 - ◇ 8.2.1.2.1 Check and replace the oil hose if any crack, heavy abrasion or leakage found.
 - ◇ 8.2.1.2.2 Check and replace the power line if any crack, abrasion or cut is found on insulating layer of power line.
 - ◇ 8.2.1.2.3 Check the cleanness inlet filter and inside of oil tank. Clean or replace filter if bad cleanness.
 - ◇ 8.2.1.2.4 Check the oil level when the platform is at lowest position. Refill if necessary.

8.2.2 Maintenance of power pack

- 8.2.2.1 Make sure the power supply is cut off and platform of parking lift is lowered down to ground before maintenance.
- 8.2.2.2 Power line, oil hose or other component is to be replaced with the same specifications.
- 8.2.2.3 The whole hydraulic system is to be depressurized completely before opened.

Note: the lifetime of hydraulic system may be affected by environment, human factor or lifetime of hydraulic components. Proper and regular maintenance could lower down probability of malfunction.

8.3 Maintenance and servicing of cylinder

Only trained and qualified staff is allowed to do inspection, maintenance and service work of cylinder.

8.3.1 Inspection of cylinder

Before installation and usage of cylinder:

- 8.3.1.1 Check if the actual working pressure and system supply pressure of cylinder is sufficient.
- 8.3.1.2 Check if hydraulic oil, working temperature and cylinder cleanness meet the requirement of sealing.
- 8.3.1.3 Check the piston surface if there is any adhered foreign particles or dirt, remove if any.
- 8.3.1.4 Check regularly if any leakage on hydraulic fluid port, piston rod, juncture of bore and piston.

8.3.2 Maintenance of cylinder

- 8.3.2.1 Clean the vent hole quarterly to keep surface of vent hole clean.
- 8.3.2.2 Keep clean hydraulic oil in hydraulic circuit by replace hydraulic oil regularly.
- 8.3.2.3 Inject lubrication oil (by injector oiler) through vent hole into lower cavity of cylinder, until lubrication oil spills from vent hole when cylinder is at maximum stroke.
- 8.3.2.4 Hydraulic fluid port and vent hole is to be well protected from dust, dirt or particles going into inside of cylinder.
- 8.3.2.5 Low-speed movement or jerky motion of rod has to be stopped and checked to avoid more damage.
- 8.3.2.6 Connection and load parts are to be checked and lubricated regularly. Loosen, galled, bent, blocked, cracked or deformed part should be replaced in time.
- 8.3.2.7 Score mark and scraping of chromium-layer on one side of piston rod surface means serious wear on one side. It's necessary to dismantle and inspect the cylinder, and replace worn part(s).
- 8.3.2.8 Check regularly hydraulic fluid port, vent hole and wiper seal at cylinder tube head end, replace the broken seals if leakage occurs.

9 Troubleshooting

9.1 Power pack

Trouble	Possible causes	Solutions
Motor is working, but cylinder does not work	The rotation of motor is in wrong direction due to incorrect motor wiring	Re-connect wires from main power supply to motor to make motor rotate with correct direction
	Not enough hydraulic oil in oil tank	Hydraulic oil to be replenished into oil tank
	Broken inlet oil pipe	Inlet oil pipe to be replaced
	Broken coupling	Coupling to be replaced
	No oil can be pumped out due to blocked inlet filter	Inlet filter to be cleaned or replaced
	Valve element of solenoid valve is blocked	Solenoid valve to be cleaned or replaced
	Sealing failure of cushion valve	Cushion valve to be cleaned or replaced
	Setting pressure of pressure relief valve is too low	Turn up setting pressure of pressure relief valve (with permission of manufacturer)
	Emergency depressurizing device of solenoid valve is not turned off	Turn off emergency depressurizing device of solenoid valve
	Broken gear pump	Gear pump to be replaced
Broken cylinder	Cylinder to be replaced	
Motor is working, but platform move up slowly	Not enough hydraulic oil in oil tank	Hydraulic oil to be replenished into oil tank CV
	Broken inlet oil pipe	Inlet oil pipe to be replaced
	fewer oil can be pumped out due to blocked inlet filter	Inlet filter to be cleaned or replaced
	Valve element of solenoid valve is blocked	Solenoid valve to be cleaned or replaced
	Sealing failure of cushion valve	Cushion valve to be cleaned or replaced
	Valve element of pressure relief valve is blocked	Pressure relief valve to be cleaned or replaced
	Setting pressure of pressure relief valve is too low	Turn up setting pressure of pressure relief valve (with permission of Mutrade)
	Hydraulic oil deteriorates or is dirty	Replace hydraulic oil, clean inlet filter and oil tank
	Broken gear pump	Gear pump to be replaced
	Broken cylinder	Cylinder to be replaced
	Emergency depressurizing device of solenoid valve is not turned off	Turn off emergency depressurizing device of solenoid valve
	Oil temperature in oil tank is out of normal range	Stop motor working to cool down hydraulic oil until it's in normal temperature

Pressure cannot be maintained after platform lifted up	Valve element of one-way valve is blocked	One-way valve to be cleaned or replaced
	Valve element of solenoid valve is blocked	Solenoid valve to be cleaned or replaced
	Fitting of outlet pipe is not fastened or sealing is broken	Fasten fitting of outlet pipe, or replace sealing
	Hydraulic oil deteriorates or is dirty	Replace hydraulic oil, clean inlet filter and oil tank
Cylinder retracts slowly when depressurizing	Throttle valve is not properly adjusted	Throttle valve to be re-adjusted
	Throttle valve is blocked	Clean throttle valve and valve element
	Valve element of solenoid valve is blocked	Solenoid valve to be cleaned or replaced
Cylinder does not retract at all when depressurizing	Valve element of solenoid valve is blocked	Solenoid valve to be cleaned or replaced
	Coil of solenoid valve is broken, or working voltage is too low	Replace coil of solenoid valve, or supply normal working voltage
Working noise is too loud, or abnormal noise	Motor is broken	Motor to be replaced
	Air is absorbed into gear pump due to lack of hydraulic oil in oil tank	Hydraulic oil to be replenished into oil tank
	Pressure relief valve is turned on to make hydraulic oil go back to oil tank due to over loading	Only cars within rated capacity can be parked on platform. Or turn up setting pressure of pressure relief valve (with permission by Mutrade)
	Inlet filter is blocked	Replace coupling and clean inlet filter
	Gear pump is broken	Gear pump to be replaced
	Hydraulic oil deteriorates or is dirty	Replace hydraulic oil, clean inlet filter and oil tank
	Pressure relief valve is broken	Pressure relief valve to be replaced
Motor does not work	Voltage shortage due to low supply voltage	Voltage stabilizer to be added
	Voltage shortage due to too long power line	Power line to be shortened, and voltage stabilizer to be added
	Voltage shortage due to too thin power line	Thicker power line to be used, and voltage stabilizer added
	Starting capacitor is broken	Starting capacitor to be replaced

9.2 Hydraulic cylinder

Trouble	Possible causes	Solutions
Jerky motion of piston rod	Aerated oil	Air to be eliminate by exhaust
	Frictional resistance is too high or changes due to improper fabrication or assembly of parts with relative motion	Reduce frictional resistance by lubrication
	Poor lubrication between surfaces of moving parts	Inlet oil pipe to be replaced
	Poor seals alignment of cylinder piston and rod	Piston and rod to be aligned
	Serious cylinder leakage	Replace seals or increase pump flow
	Overlarge minimum stable flow of flow valve	Flow valve with small minimum stable flow to be employed
	Flexible hose employed between cylinder and flow valve	Replaced by nonflexible hose
	Frictional resistance increases due to abrasive particles in oil	Clean hydraulic elements, and replace hydraulic oil and filter
Pressure shock	Overlarge cushion clearance	Reduce cushion clearance
	One-way valve/throttle valve failure in cushion device	One-way valve/throttle valve to be repaired
	Overlarge pressure in cushion chamber due to undersized volume	Diameter and length of cushion chamber to be increased
Insufficient thrust or lowered motion speed	Oversize or undersize fit clearance between bore and piston, broken or too tight seals result in inner leakage or large moving resistance	Repair or replace part with wrong size and accuracy. Seals to be re-assembled, adjusted or replaced
	Bent piston rod results in intense friction	Piston rod to be straightened
	manufacture errors or poor assembly of moving parts results in decentration or intense friction on one side	Repair parts with errors, or re-assemble
	Scratch on bore results in blocked piston, or poorly processed bore	bore honing, repair or replace cylinder tube
	Contaminated oil by too much foreign particles makes piston or piston rod blocked	Clean hydraulic circuit, and replace hydraulic oil
	Too high oil temperature results in more leakage	Find out the reason of oil temperature rising and amend seal structure to lower down oil temperature
	Insufficient oil supply of power pack	Power pack to be repaired or replaced
	Too high oil return resistance in hydraulic return line	Diameter of oil return pipe to be enlarged, turn down the pressure of back pressure valve
Too low setting pressure or regulating failure of pressure relief valve	Turn up setting pressure, or fix pressure relief valve	

Leakage	Galling, scratch or damage of seal	Seal to be replaced
	Wrong direction of seal	Sealing direction to be corrected
	Voltage shortage due to low supply voltage	Screw to be tightened
	Longitudinal scratch or groove mark between moving parts inside cylinder body	Parts to be repaired or replaced
	Vibration of inlet and outlet pipes results in loosening	Tighten oil pipes, or amend connection type
Noise	Contaminated oil by air	Air to be eliminated by exhaust
	Too tight clearance between relative sliding surfaces	To be re-assembled with proper clearance
	Too high sealing friction, lack of lubrication on sling surface	Bottom diameter and width of seal groove, compression amount of seals to be correctly designed and manufactured
	Deformed or damaged guiding support ring	Guiding support ring to be repaired or replaced