

P/AM *OVE*



FASTER EFFORTLESS
CONCRETE CHIPPING

AVERAGE PRODUCTION BOOST UP TO 4X

PATENT CA # 2 415 330 USA # US6 752221B1

FASTER AND EFFORTLESS CONCRETE CHIPPING FOR OVERHEAD AND VERTICAL SURFACES AVERAGE PRODUCTION BOOST UP TO 4X

ELIMINATES HAMMER WEIGHT, VIBRATION
AND DEAD BLOWS

PATENTED TECHNOLOGY OFFERING
UNRIVALED RESULTS

EASY TO USE, LOW MAINTENANCE
AND EASILY TRANSPORTED

EQUIPMENT FULLY PAID
AFTER ONLY 3250 FT²*

POSSIBLE TO INSTALL ANY KIND
OF HAMMERS, ROCK DRILLS
AND HYDRO-DEMOLITION LANCES

OVER 250 UNITS

SOLD IN NORTH AMERICA

* Based on labor cost of \$50/hr,
3x productivity boost and a 40-hr work week



PARKING GARAGE

MOTION RANGE

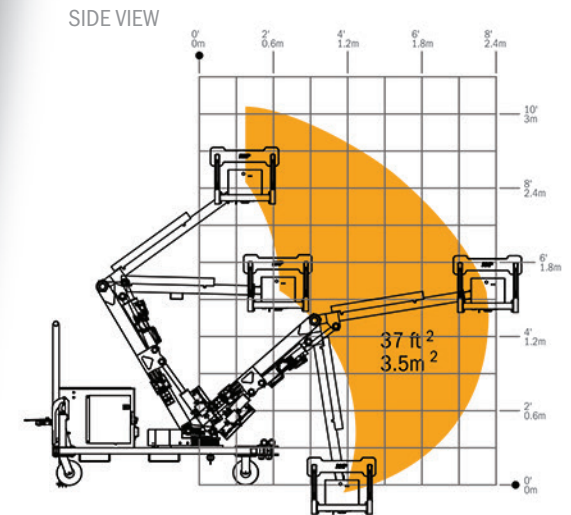

FEATURES & SPECIFICATIONS

- Mount 15 lb (7kg) chipping hammer, 35 lb (16 kg) rivet buster, 65 lb (29kg) paving breaker (optional), rock drills, hydro-demo lances and other tools
- Designed to push the tool against the surface, eliminating dead blows
- Water nozzle for dust control
- Air powered over hydraulic and electric
- 96° swing lock hydraulic knuckle boom

INFRASTRUCTURE





CHIMNEY AND STACK

TOP VIEW

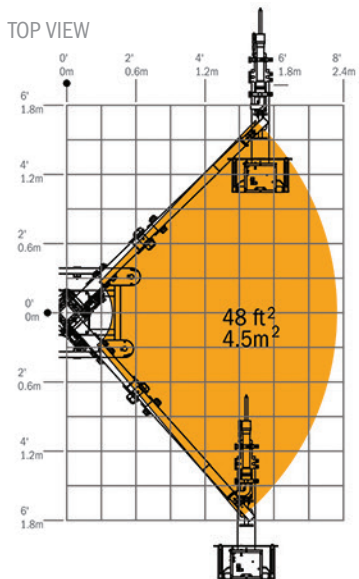

EXPERT CHOICE AWARD
DEMOLITION & REPAIR 2008



PROUD MEMBER OF:



- 4 caster wheels and 2 removable 21" (53 cm) wheels
- 3 outriggers for stability
- Fingertip controls
- Unit air consumption of 25 CFM (700 l/min) @ 90 psi (620 kPa)
- Total weight without tool of 1150 lbs (525 Kg)
- Frame size 31 1/2" X 72" (80 cm x 183 cm) without removable wheels
- Self-contained, no harmful emissions



DRILLING



MASONRY DEMOLITION



CALL FOR A DEMO
888 697 5355

SEE MORE AT **RNPIND.COM**



RNP
INDUSTRIES

112 Prévost Blvd.
Boisbriand, (Quebec) Canada
J7G 2S2

Toll free: 1 888 697-5355
Email: info@rnpind.com
Tel.: (450) 437-5355
Fax: (450) 437-2651

WWW.RNPIND.COM