

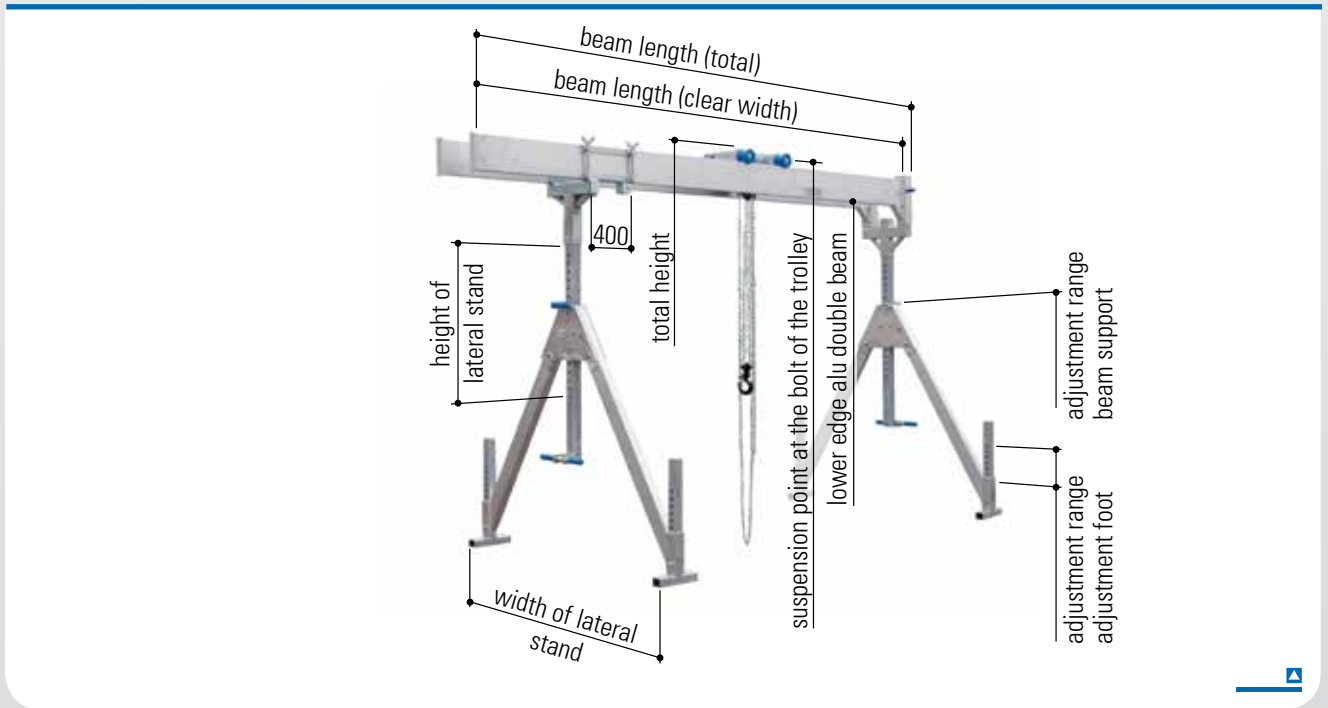

Aluminium Gantry Cranes, stationary model, with double beam, load capacity 2,000 kg and 3,000 kg



item no.	load capacity	beam length		suspension point at the bolt of the trolley		total height		lower edge alu double beam		adjustment range		lateral stand		weight
		clear width	total	min.	max.	min.	max.	min.	max.	beam support	adjustment foot	width	height	
	kg	mm	mm	mm	mm	mm	mm	mm	mm	mm	mm	mm	mm	kg
2,000 kg		Please find details for this Aluminum Gantry Crane on page 26.												
1532040	2,000	4,000	4,100	2,640	3,790	2,730	3,880	2,380	3,530	750	400	2,230	1,960	248
1532050	2,000	5,000	5,100	2,640	3,790	2,730	3,880	2,380	3,530	750	400	2,230	1,960	266
1532060	2,000	6,000	6,100	2,640	3,790	2,730	3,880	2,380	3,530	750	400	2,230	1,960	284
1532070	2,000	7,000	7,100	2,640	3,790	2,730	3,880	2,380	3,530	750	400	2,230	1,960	302
1532080	2,000	8,000	8,100	2,640	3,790	2,730	3,880	2,380	3,530	750	400	2,230	1,960	384
3,000 kg		Please find details for this Aluminum Gantry Crane on page 27.												
1533040	3,000	4,000	4,100	2,640	3,790	2,730	3,880	2,380	3,530	750	400	2,230	1,960	248
1533050	3,000	5,000	5,100	2,640	3,790	2,730	3,880	2,380	3,530	750	400	2,230	1,960	306
1533060	3,000	6,000	6,100	2,640	3,790	2,730	3,880	2,380	3,530	750	400	2,230	1,960	332



Aluminium Gantry Cranes, stationary model, with double beam, load capacity 2.000 kg

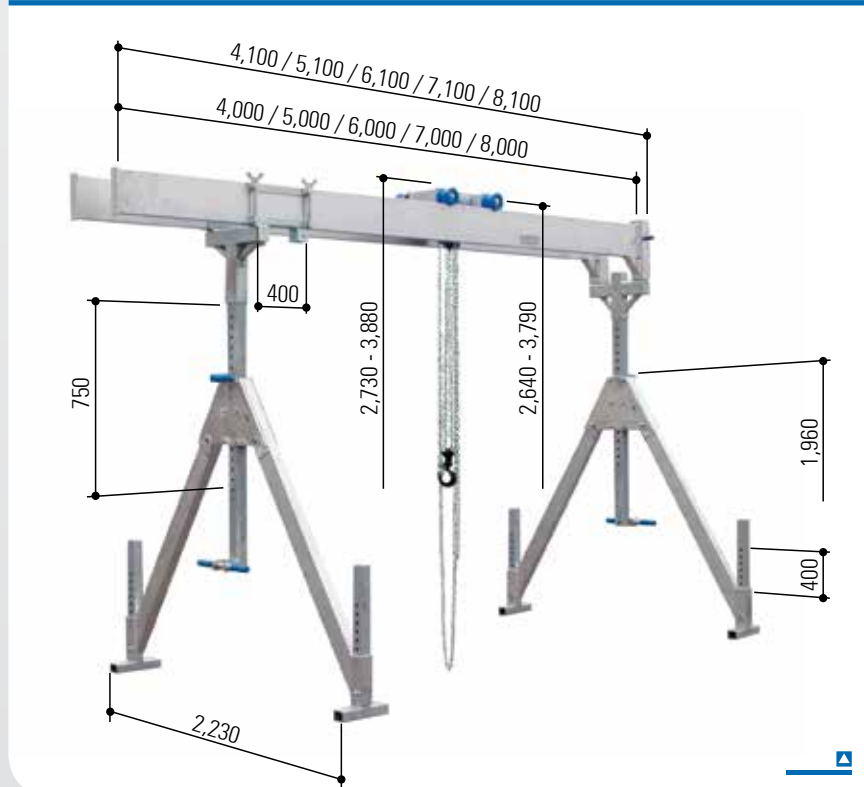

with collapsible lateral stands
incl. top-mounted park-brake trolley
incl. integrated horizontal adjuster
incl. beam mountings

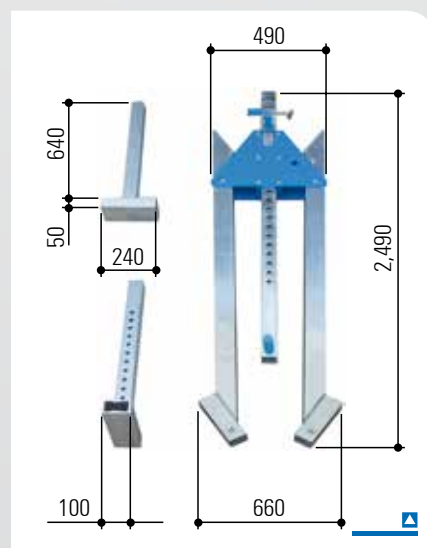

Accessories

- ▣ Wall Bracketpage 78
- ▣ Wheel Kitpage 79
- ▣ Crane Transporterpage 80
- ▣ Chain Hoistpage 81
- ▣ Electric Chain Hoistpage 82
- ▣ Cable System / Power Supplypage 83
- ▣ Manual Trolley Direction Band ...page 84
- ▣ Hand Winchpage 84
- ▣ Lateral Extension Beampage 85
- ▣ Packing and Transportation
Boxpage 86

Alternatives

- ▣ separable resp. pluggable
Aluminium Double Beam page 28

folded lateral stand



Technical Data

item no.		1532040	1532050	1532060	1532070	1532080
load capacity	kg	2,000	2,000	2,000	2,000	2,000
beam length	mm	4,000	5,000	6,000	7,000	8,000
beam support	mm	81 x 81	81 x 81	81 x 81	81 x 81	81 x 81
beam profile	mm	220 x 60	220 x 60	220 x 60	220 x 60	220 x 60*
beam housing		one side: sleeve 92 x 92 mm, 380 mm long; other side: end piece				
clear width alu beam	mm	250	250	250	250	250
total weight	kg	248	266	284	302	384
aluminium beam	kg	2 x 39	2 x 48	2 x 57	2 x 66	2 x 107
lateral stand	kg	2 x 60	2 x 60	2 x 60	2 x 60	2 x 60
trolley	kg	17	17	17	17	17
horizontal adjuster	kg	23	23	23	23	23
beam mounting	kg	10	10	10	10	10

* with larger profile thickness (inwards)

Please find an overview of this Aluminium Gantry Crane on page 25.



Aluminium Gantry Cranes, stationary model, with double beam, **load capacity 3.000 kg**

with collapsible lateral stands
incl. top-mounted park-brake trolley
incl. integrated horizontal adjuster
incl. beam mountings

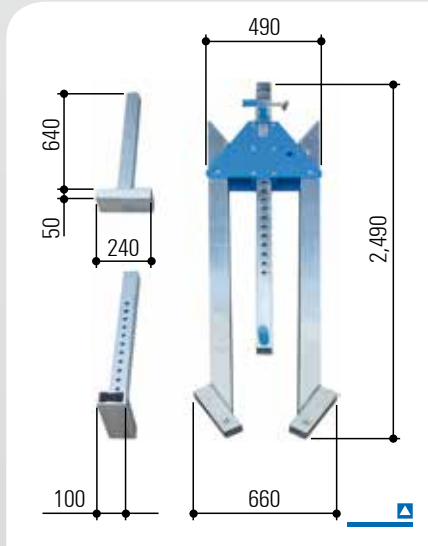

folded lateral stand

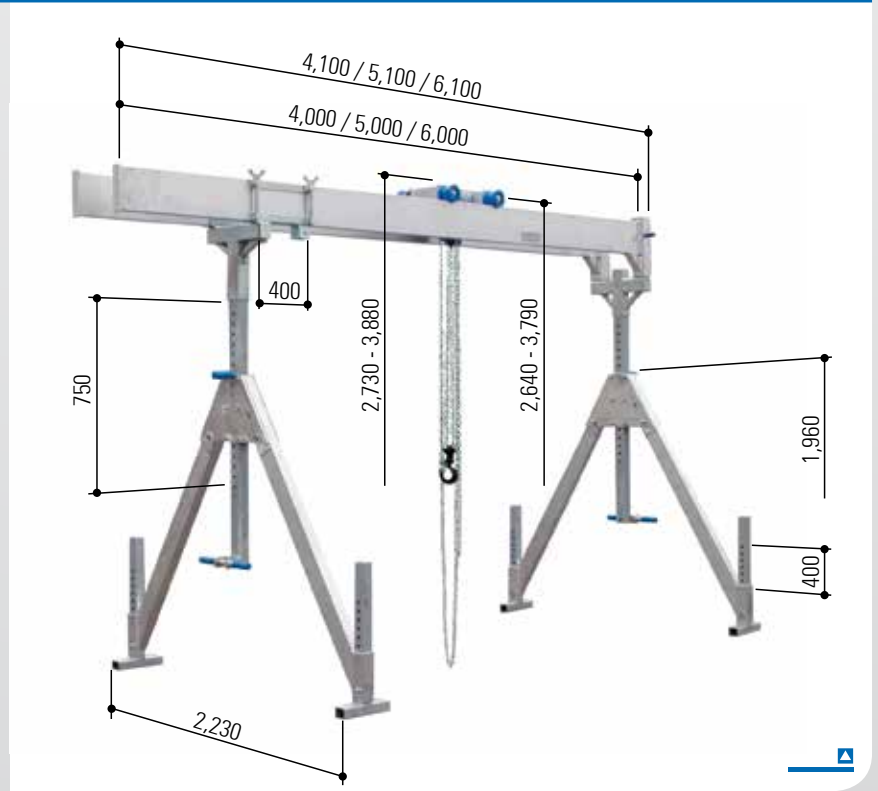

Alternatives

- separable resp. pluggable Aluminium Double Beam page 28

Accessories

- Wall Bracket page 78
- Wheel Kit page 79
- Crane Transporter page 80
- Chain Hoist page 81
- Electric Chain Hoist page 82
- Cable System / Power Supply page 83
- Manual Trolley Direction Band ... page 84
- Hand Winch page 84
- Lateral Extension Beam page 85
- Packing and Transportation Box page 86

Technical Data

item no.		1533040	1533050	1533060
load capacity	kg	3,000	3,000	3,000
beam length	mm	4,000	5,000	6,000
beam support	mm	81 x 81	81 x 81	81 x 81
beam profile	mm	220 x 60	220 x 60*	220 x 60*
beam housing		one side: sleeve 92 x 92 mm, 380 mm long; other side: end piece		
clear width alu beam	mm	250	250	250
total weight	kg	248	306	332
aluminium beam	kg	2 x 39	2 x 68	2 x 81
lateral stand	kg	2 x 60	2 x 60	2 x 60
trolley	kg	17	17	17
horizontal adjuster	kg	23	23	23
beam mounting	kg	10	10	10

* with larger profile thickness (inwards)

Please find an overview of this Aluminium Gantry Crane on page 25.



separable resp. pluggable Aluminium Double Beam



Picture: Aluminium Gantry Crane, stationary model, with single beam



The separable resp. pluggable Aluminium Double Beam!

This latest addition is a consequence of further development of our extensive assortment of Cranes and Accessories. Through our own aspirations in optimisation we now bring you – the separable resp. pluggable Aluminium Double Beam.

An innovation for our customers

Through your wishes for speed, innovation and optimisation and further more high-end quality products we want to inspire you.

As we are able to offer our aluminium lateral stands with the alternative of being collapsible, we have now taken the longest and most cumbersome part in our delivery programme and enabled it to be separable resp. pluggable Aluminium Double Beam.

Both separated beam pieces can also be used as single Aluminium Double Beams as well.

Save even more space

- ▣ Purchase a complete Aluminium Gantry Crane including the separable resp. pluggable Aluminium Double Beam.
- ▣ Upgrade your already existing Aluminium Gantry Crane.

This separable resp. pluggable Aluminium Double Beam is suitable for Aluminium Gantry Cranes detailed on pages 24 to 27.

The Item number consists of:

New Aluminium Gantry Crane: Item number of the standard crane (compare pages 24 to 27) -**10**

Examples:

Aluminium Gantry Crane, stationary model, double beam medium, load capacity 3,000 kg

- ▣ with 'Standard' Aluminium Double Beam, beam length 4,000 mm: item no. 1533040
- ▣ with 'separable resp. pluggable' Aluminium Double Beam, beam length 4,000 mm: item no. 1533040-10